

## Keysight Basic Instruments

May-July 2015

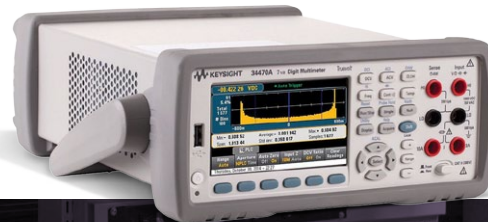

New DMMs with lower current ranges make pA measurements easier than ever before

SEE PAGE 3



 **KEYSIGHT**  
TECHNOLOGIES

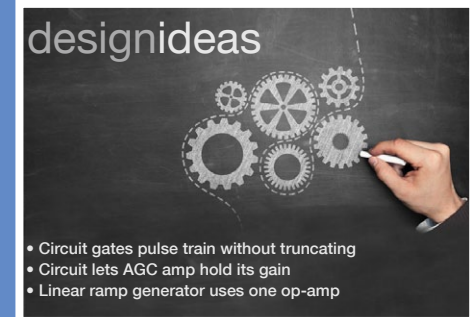

  
**Open  
Accounts  
Available**  
For Qualifying Customers

**DIGIKEY.COM/EUROPE**



# EDN

# europa

SEPTEMBER 2015

[www.edn-europe.com](http://www.edn-europe.com)

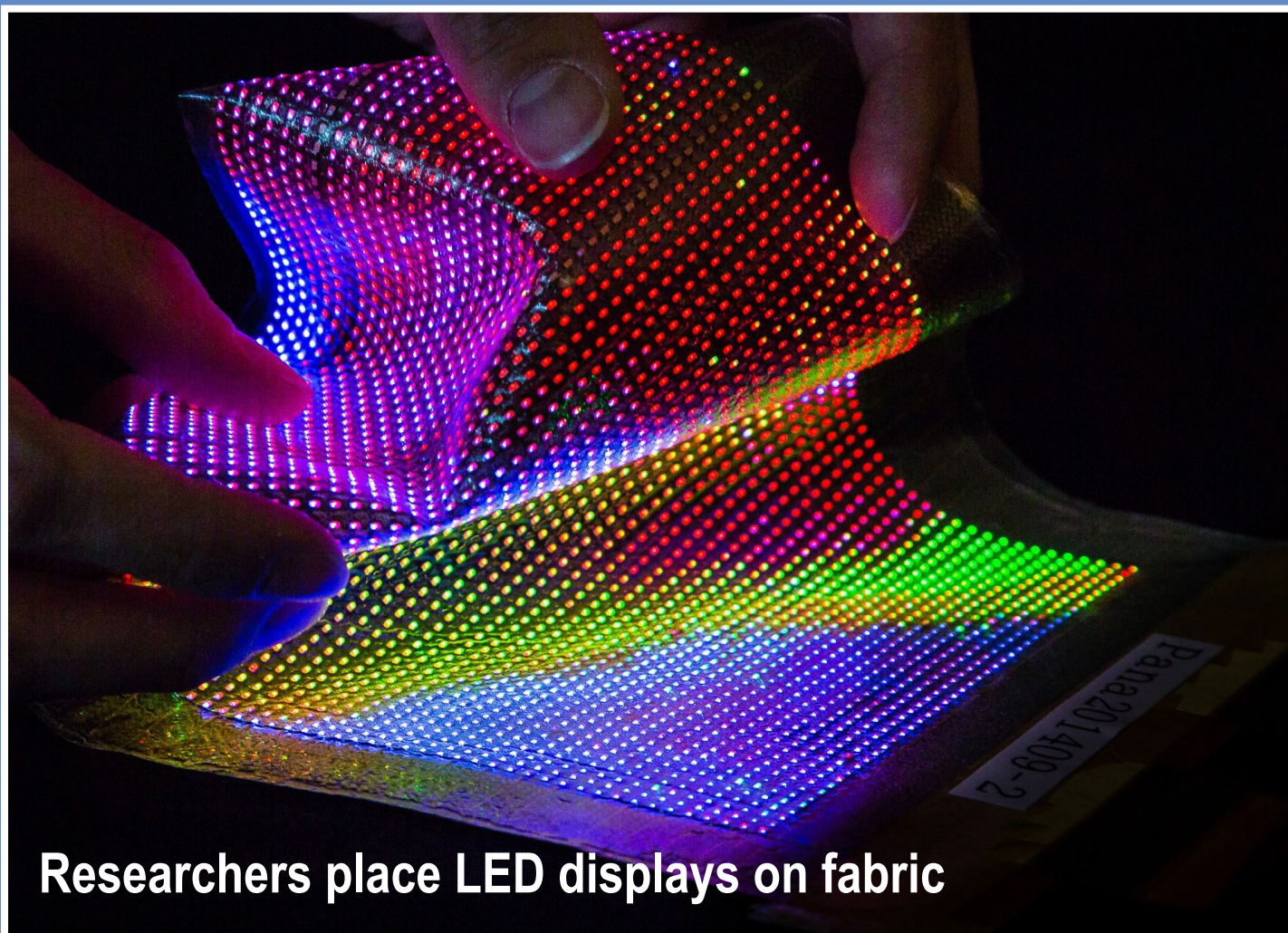

Researchers place LED displays on fabric

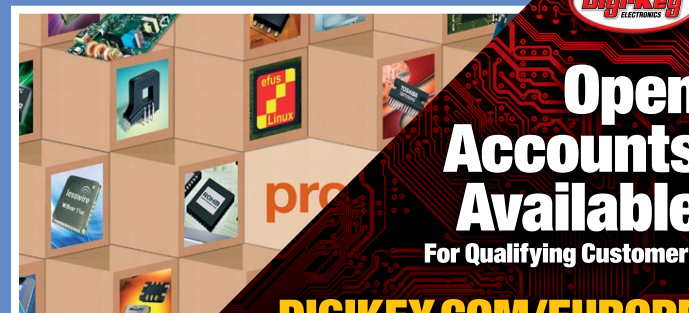
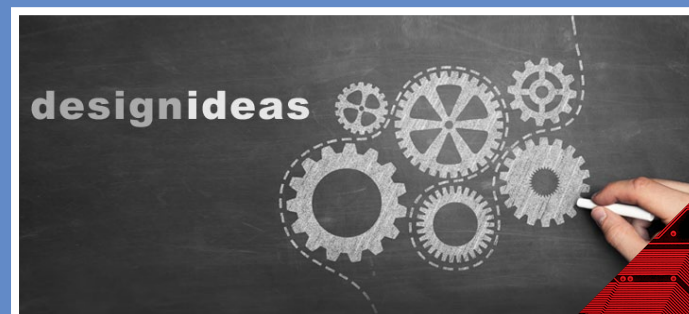
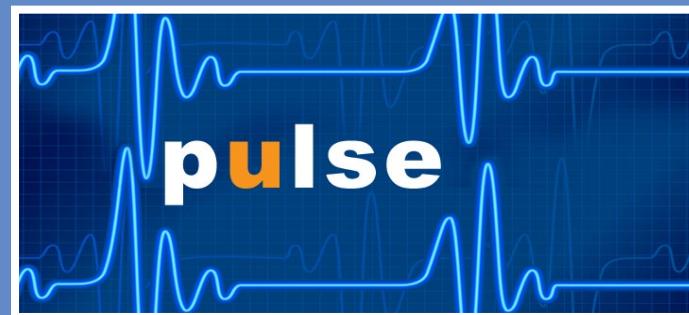

**Digi-Key**  
ELECTRONICS

**Open  
Accounts  
Available**

For Qualifying Customers

**DIGIKEY.COM/EUROPE**



# THE WORLD'S LARGEST SELECTION OF ELECTRONIC COMPONENTS AVAILABLE FOR IMMEDIATE SHIPMENT!™



**FREE SHIPPING ON ORDERS OVER €65\***



**OPEN ACCOUNTS AVAILABLE FOR QUALIFYING CUSTOMERS**



**LOCAL SALES & TECHNICAL SUPPORT**

**FEATURING:  
THE NEWEST PRODUCTS  
AND TECHNOLOGY**



**FIND CONTACT AND ORDERING INFORMATION FOR YOUR REGION AT  
DIGIKEY.COM/EUROPE**

**1,000,000+ PRODUCTS IN STOCK | 650+ INDUSTRY-LEADING SUPPLIERS | 3.9 MILLION PARTS ONLINE**

\*A shipping charge of €18.00 (£12.00) will be billed on all orders of less than €65.00 (£50.00). All orders are shipped via UPS for delivery within 1-3 days (dependent on final destination). No handling fees. All prices are in euro and British pound sterling. If excessive weight or unique circumstances require deviation from this charge, customers will be contacted prior to shipping order. Digi-Key is an authorized distributor for all supplier partners. New product added daily. © 2015 Digi-Key Electronics, 701 Brooks Ave. South, Thief River Falls, MN 56701, USA

## COVER

### Displays on clothing fabrics

Researchers from Holst Centre (Eindhoven, the Netherlands), imec (Leuven, Belgium) and CMST, imec's associated lab at Ghent University, have demonstrated the world's first stretchable and conformable thin-film transistor (TFT) driven LED display laminated into textiles. The work paves the way, say the researchers, to wearable displays in clothing providing users with feedback. The conformable display is very thin and mechanically stretchable. A fine-grain version of the proven meander interconnect technology was developed by the CMST lab at Ghent University and Holst Centre to link standard (rigid) LEDs into a flexible and stretchable display. The LED displays are fabricated on a polyimide substrate and encapsulated in rubber, allowing the displays to be laminated in to textiles that can be washed. Importantly, the technology uses fabrication steps that are established in the manufacturing industry, enabling rapid industrialisation. Smaller LEDs are now mounted on an amorphous indium-gallium-zinc oxide (a-IGZO) TFT backplane that employs a two-transistor and one capacitor (2T-1C) pixel engine to drive the LEDs. These second-generation displays offer higher pitch and increased, average brightness. The generation now being presented is shown as a 32 x 32 pixel demonstrator with a resolution of 13 pixels per inch (ppi) and average brightness above 200 candelas per square meter (cd/m<sup>2</sup>). More [here](#).

## FEATUREARTICLES

### 22 Non-isolated offline quasi-resonant flyback converter

by Florian Mueller, Texas Instruments

### 20 It's not a feature, it's a bug...

by Johan Kraft, Perceptio AB

### 16 Higher linearity in RF/IF amps eases design challenges

by Greg Fung, Linear Technology

### 27 Designing with DesignSpark tools

by Pete Wood, RS Components

## ONLINE THIS MONTH

### The DreamBoard project – probing tomorrow's global electronic trends

by Dianne Kibbey, element14

### A 3-part series on privacy & security issues in the IoT & here & here

by Simon Moffatt, ForgeRock

### Resistors aren't resistors

by Kenneth Wyatt

### Are you bored with your board? - PCB material for extreme applications

by Rajan Bedi, Spacechips

## EDN's columns

### 5 EDN.comment

Persistence of memory

### 6 Pulse

Bipolar analogue supply rail IC; 40 GHz handheld spectrum analyser; Raspberry Pi sensor board; Wireless charging eval kit; Tiny energy-harvesting PMIC; 4-mm sq. GPS module; Ethernet for vehicles; Twin high-density flash structures

### 24 Analog Tips

SFDR for ADCs

by Ian Beavers, Analog Devices

### 18 Power Points

New Horizons spacecraft's power issues make yours look trivial

by Bill Schweber, EDN

### 39 Tales from the Cube

The downsides of tech complexity

by Brian Dipert, EDN

### 34 Product Roundup

Raspberry Pi + Simulink bundle; Near-ideal power MOSFETs; HEV current sensors; Multi-cell Li-ion monitor; Ultra-low power regulator; USB to Gbit Ethernet conversion; Complete Bluetooth connectivity module

### 29 Design Ideas

30 AC power measurement uses PWM & PAM

32 Fast, low-noise JFET amp is stable over temperature



# Scalable Automotive Network Solutions

Cost-Efficient • Real-Time • Flexible



Microchip has been delivering robust, automotive-qualified CAN, LIN, Ethernet, MOST® technology and USB solutions to automotive suppliers for over ten years. Our MOST technology and USB solutions are the de facto standards for in-vehicle infotainment and consumer device connectivity worldwide. If your automotive design requires in-vehicle transport of audio, video, control or Ethernet packet data, we offer solutions which work reliably over UTP, coax and optical physical layers with guaranteed low latency. Software stacks are also available from Microchip, as well as third parties, allowing you to focus your efforts on application software development.

## Application Examples

- ▶ Body control
- ▶ Rear-view camera
- ▶ Top-view camera
- ▶ LTE/3G connectivity
- ▶ HMI
- ▶ Infotainment head unit
- ▶ Ambient LED lighting
- ▶ Exterior LED lighting
- ▶ Smart sensors

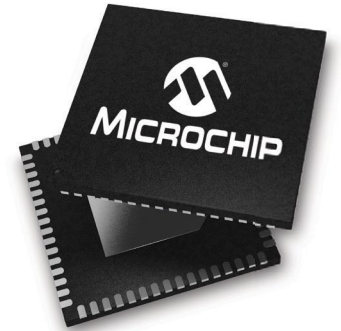

**microchip**  
**DIRECT**  
[www.microchipdirect.com](http://www.microchipdirect.com)

 **MICROCHIP**

[www.microchip.com/automotive](http://www.microchip.com/automotive)

## PERSISTENCE OF MEMORY

One slow news day this summer, an instance of technology fragility hit the headlines. In a particularly severe electrical storm in Belgium, one of Google's data centres lost a little bit of data. Google's [statement](#) on the subject says; "At 09:19 PDT on Thursday 13 August 2015, four successive lightning strikes on the local utilities grid that powers our European datacenter caused a brief loss of power to storage systems which host disk capacity for GCE [Google Compute Engine] instances in the europe-west1-b zone. Although automatic auxiliary systems restored power quickly, and the storage systems are designed with battery backup, some recently written data was located on storage systems which were more susceptible to power failure from extended or repeated battery drain. In a very few cases, recent writes were unrecoverable, leading to permanent data loss on the Persistent Disk.... In total, approximately 5% of the Standard Persistent Disks in the zone experienced at least one I/O read or write failure.... by Monday 17 August, only a very small number of disks remained affected, totalling less than 0.000001% of the space of allocated persistent disks in europe-west1-b. In these cases, full recovery is not possible." To completely understand that, you need to have a grasp of the specific meaning of "persistent" in the context of servers and compute farms – we'll leave that as an

"exercise for the reader" (you can always Google it!). The point, however, is that it reminds us that nothing in the storage field is forever, not even "the cloud". It's a point that my US colleague Bill Schweber made in a recent column, "[Are you using the cloud as your time capsule?](#)": are you choosing cloud-based storage as a backup, or even primary repository, for key project information, or personal information, or family documents, photographs, and the like?

It's a reasonable choice; we all know that hard discs can (do) suffer catastrophic failures; flash memory (being charge-storage-based) has a finite retention period; CD/DVD media have been known to deteriorate in not-too-many years, as can magnetic tape substrates. And so on. Not to mention the fact of format obsolescence – you can find yourself (as entities such as NASA, anecdotally, have) with data that you no longer have any means of reading. (Zip-disc, anyone?)

Bill writes; *"I understand the role and some benefits of the cloud as a data-storage and interchange medium, but that alone is not a game-changer to me. My concern is that the cloud is being touted as the place for archival, long-term storage of anything and everything, beyond being primarily used for sharing files and applications among co-workers and*

*family. "Long term" is a complicated business, especially when you start talking about years and extend it to decades.*

*"I was reminded about this reality by a recent article in The Wall Street Journal, "Trying to Capture a Moment, Many Lose Track of Time" (Sorry, it may be behind their paywall). In brief, it turns out that most physical time capsules are soon lost. Within a short period of even just a few years, people forget about them, the documentation about their existence is misplaced, they physically deteriorate, or their location becomes inaccessible, among the many things that do happen to them."*

That, we might note, is in the context of information already sorted and selected for archiving. Who among us is disciplined enough to sort and prune their documents, photos and videos? If you are that person, I apologise: but we are all now equipped to generate gigabytes of data and are provided with corresponding gigabytes – terabytes, in fact – of storage that is free, or nearly so. Whatever the chosen medium, we happily load large tranches of data into it, confident that it will always be there, intact and searchable, when needed.

Have you evolved a personal strategy for maintaining data integrity for your essential "content"?





## Power supply IC generates low-noise bipolar (+/-) power rails

**L**TTC3265 is a high voltage, highly integrated, low noise dual output power supply IC which takes a single positive input supply ( $V_{IN\_P}$ ) and generates low noise bipolar rails up to  $\pm 2 \cdot V_{IN\_P}$  without any inductors. High voltage boost and inverting charge pumps deliver low noise dual outputs with post-regulating  $\pm 50$  mA low-dropout regulators (LDOs).

The boost charge pump has a 4.5V to 16V input range and powers the positive LDO post regulator from its output,  $V_{OUT+}$ . The inverting charge pump has a wider input range (4.5V to 32V) which may be connected to either the boost input or output. The negative LDO post regulator is powered from the output of the inverting charge pump,  $V_{OUT-}$ . The LTC3265 is suited for a variety of applications that require low noise bipolar supplies from a high voltage input.

The positive and negative LDO regulators can source up to 50 mA of output current, each with

100  $\mu$ V RMS output noise, and their output voltages can be in-

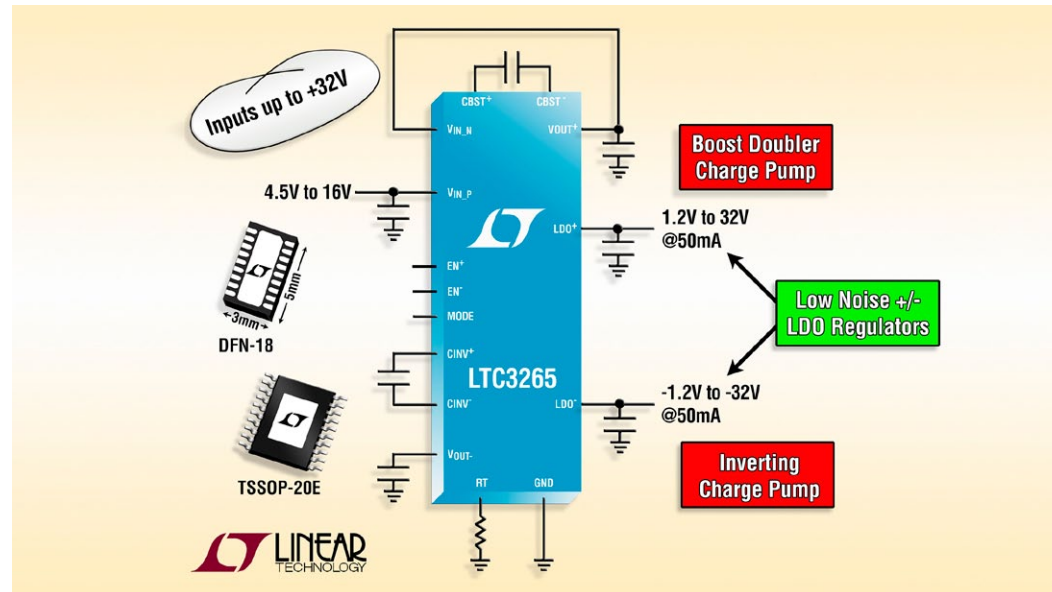

dependently adjusted from  $\pm 1.2$ V to  $\pm 32$ V using external resistor dividers to generate symmetric or asymmetric output supply rails. The internal charge pumps of the LTC3265 function in either low quiescent current Burst Mode operation for highest efficiency, or constant frequency mode for lowest noise. In Burst Mode op-

eration, the LTC3265 draws 135  $\mu$ A of quiescent current with both LDO regulators on, at no load. In constant frequency mode the part operates at a fixed 500 kHz, or at a programmed value between 50

kHz and 500 kHz using an external resistor. Other IC features include low external parts count, stability with ceramic capacitors, soft-start circuitry to prevent excessive current flow during start-up, plus short-circuit and thermal protection.



## Hand-held spectrum analyser measures to 40 GHz

**F**rom distributor Link Microtek; this hand-held spectrum analyser, that is not much larger than a smartphone, is able to carry out measurements on microwave signals at frequencies as high as 40 GHz. Manufactured by **SAF Tehnika** (Riga, Latvia), the Spectrum Compact instrument is primarily aimed at field engineers dealing with commercial mobile-phone infrastructure, satellite communications links or military communications systems.

It is suitable for the planning, installation, maintenance and troubleshooting of microwave networks, and its receiver sensitivity of -105 dBm enables even weak signals to be detected and analysed. Typical applications include antenna alignment, interference detection, cross-polarisation adjustment and measurement of antenna gain.

The instrument incorporates a



50Ω SMA input, which enables it to be connected to almost any antenna using standard waveguide flange adapters. There is also a mini USB port for recharging the polymer lithium-ion batteries and transferring saved spectrum scans



to a PC for enhanced data analysis using the Spectrum Manager software supplied with the unit.

Available in five different models covering frequency bands from 2 to 40 GHz, Spectrum Compact has overall dimensions of 130 x 81 x 28 mm and a maximum weight of only 400g.

[Complete article, here](#)

## Pis in Space... Raspberry Pi Sense HAT sensor board

Distributor element14 has the latest addition to the expanding ecosystem of Raspberry Pi accessories; the Raspberry Pi Sense

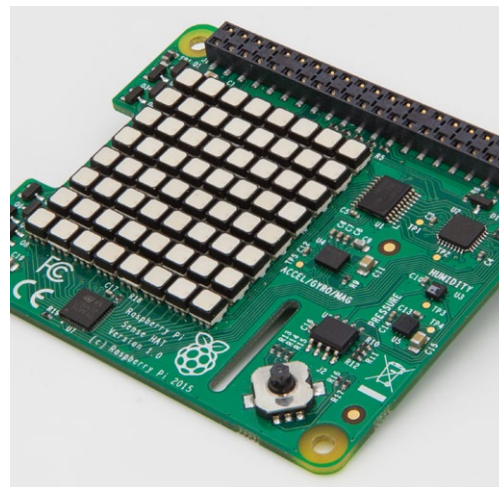

HAT, as featured in the 'Astro Pi' space mission. The Sense HAT will enable enthusiasts to control the same hardware used in space. The Sense HAT attaches to the Raspberry Pi board, and can be used for many different types of experiments, applications and games, including those due to be carried out on the International Space Station by UK ESA Astronaut Tim Peake.

The Sense HAT is compatible with Raspberry Pi 2, and Raspberry Pi 1 models B+ and A+, and connects to the Raspberry Pi via the 40 GPIO pins. Specifications and functions include:

- Gyroscope – angular rate sensor:  $\pm 245/500/2000$ dps (degrees/sec)
- Accelerometer - Linear acceleration sensor:  $\pm 2/4/8/16$  g
- Magnetometer - Magnetic Sensor:  $\pm 4/8/12/16$  Gauss
- Barometer: 260 – 1260 hPa absolute range (accuracy depends on the temperature and pressure,  $\pm 0.1$  hPa under normal conditions)
- Temperature sensor (Tem-

perature accurate to  $\pm 2$ C in the 0-65C range)

- Relative Humidity sensor (accuracy to  $\pm 4.5\%$  in the 20-80%rH range, accurate to  $\pm 0.5$ C in 15-40C range)
- 8 x 8 LED matrix display
- Small 5 button joystick

[Complete article, here](#)

**TAKE A LOAD OFF**  
 WITH CORE INDEPENDENT PERIPHERALS



## Plug-&-play kits to explore & evaluate wireless charging

IDT says it is, “making wireless power accessible to the mass market”; eliminating prior barriers, these reference kits aim to assist engineers to integrate wireless charging into product designs. Integrated Device Technology’s turnkey wireless power kits are intended to simplify integrating wireless charging and to make it affordable and practical for a broad range of consumer electronics. The Qi-compliant transmitter and

receiver reference kits promise plug-and-play ease of integration, enabling engineers to incorporate wireless charging capabilities into designs in a matter of hours. The 5-W, 5-V configuration is suitable for a wide range of applications, including PC peripherals, furniture, medical devices, and other portable devices. The transmitter and receiver reference kits are built around IDT wireless power ICs, and include



reference boards and design support material. There are instructional videos, user manuals, foreign object detection (FOD) tuning guides, layout guides, layout instantiation modules, schemat-

ics, bill-of-materials (BOM), and Gerber files. Both reference kits offer 2-layer board layout files, providing maximum flexibility for most applications. The boards are Qi-compliant for use as-is. An unboxing and start-up video is [here](#). The P9038-R-EVK and P9025AC-R-EVK are \$40 and \$30, respectively. For the best prototyping and evaluation experience, IDT recommends ordering both the transmitter and receiver kits; the company says that “limited quantities” are available.

Complete article, here

## 10-cell Li-ion monitor IC operates stand-alone, without MCU supervisor

Aimed at portable products such as cordless vacuum cleaners and electric tools, Lapis Semiconductor’s 10-cell lithium-ion battery monitoring LSI features current consumption of only 25  $\mu$ A (typ.), claimed as the lowest available, for battery protection systems in portable equipment. The ML5233 also features 0.1  $\mu$ A (typ.) current consumption during power down, minimising

the effects on battery capacity - even during long-term storage - with virtually no loss of charge. Built-in temperature and short-circuit current detection circuits enable detection of not only over-charge/discharge and overcurrent, but also abnormal (high) temperatures during discharge along with battery pack short-circuits - all without an MCU. This decreases footprint by 20% and reduces the number of

■ ML5233 10-Cell System Configuration

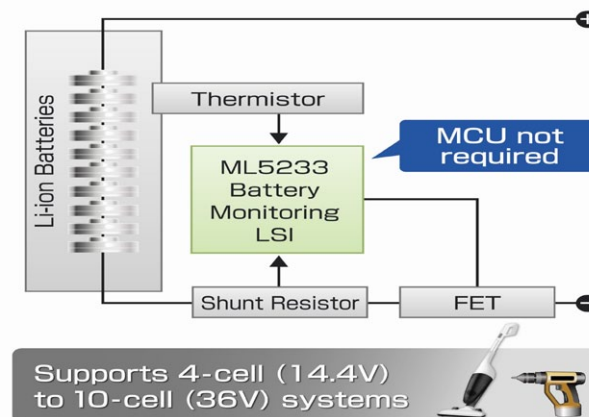



external components from four to one, leading to smaller battery protection systems and lighter development load. In operation, high overcharge detection accuracy ( $\pm 15$  mV per each cell) increases charging efficiency by 7% over conventional products that feature  $\pm 50$  mV accuracy. Multiple abnormality detection and protection features implemented without a microcomputer reduces footprint by 20%. Scalable multi-stage series connection supports systems with more than 10 cells; high-voltage processes support 4-10 cells in series using a single LSI, ensuring compatibility with electric tools and other equipment in the 14V to 36V range. The design enables scalability to support a wider range of applications. For example, two LSIs can be combined to support up to 20 cells in series and up to 72V, for pedal-assisted bicycles, ride-on carts, and other high voltage applications.



## Energy-harvesting power management ICs for wireless sensor nodes

Cypress Semiconductor has introduced what it believes to be the lowest-available-power PMICs (power management ICs) that enable an integrated module size of 1 cm<sup>2</sup> for solar-powered wireless sensor node (WSN) designs. Intended to manage solar-powered wireless sensors for Internet of Things (IoT) applications, these parts are said to be the lowest-power, single-chip energy-harvesting PMICs, and can be used with solar cells as small as 1 cm<sup>2</sup>. Cypress offers a complete, battery-free energy harvesting solution that pairs the S6AE101A PMIC, the first device in the new family, with the EZ-BLE PProC module for Bluetooth Low Energy connectivity, along with supporting software, in a \$49 kit. The Cypress Energy Harvesting PMIC devices offer a startup power of 1.2  $\mu$ W – one-quarter that of the nearest competitor, Cypress asserts – and current consumption

as low as 250 nA, maximising the power available for the sensing, processing and communications functions of a target application. The fully-certified, small-form-factor EZ-BLE PProC module, which is based on Cypress's PProC BLE Programmable Radio-on-Chip solution, works with the PMIC devices to contribute to the low power and ease-of-use of an energy harvesting system solution. The EZ-BLE PProC module provides an end-to-end Bluetooth Low Energy solution that includes Bluetooth 4.1 qualification and is compliant to wireless regulatory standards in the U.S., Canada, Japan, Korea and Europe. The module integrates the programmability and ARM Cortex-M0 core of PProC BLE, two crystals, an on-board chip antenna, metal shield and passive components, all in a 10 x 10 x 1.8-mm form factor. Engineers designing with the module can apply to add the Bluetooth logo on their products by referring

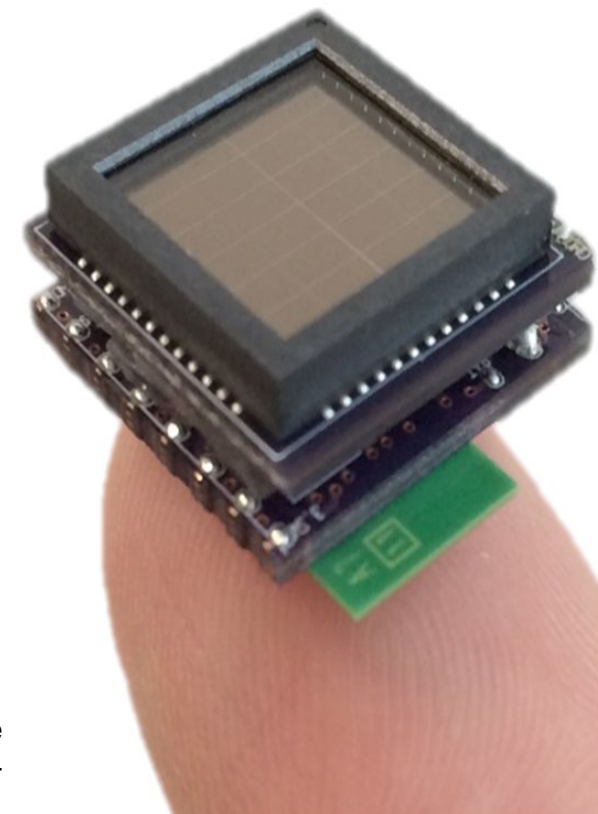

to Qualification Design Identification (QDID) 67366, assigned to Cypress by the Bluetooth SIG.

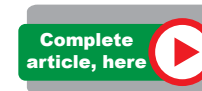

## Open-source hardware formats meet industrial controls

Distributor RS Components has the Industrial Shields brand of PLCs (programmable logic controllers) and panel PCs; the range builds on Arduino, Hummingboard and Raspberry Pi boards to deliver open-source advantages on ready-to-use, approved hardware.

The PLC portfolio comprises **ARDBOX** compact PLCs based on the Arduino Leonardo board, and **M-DUINO** Ethernet PLCs based on the Arduino Mega board. All operate from a supply voltage of 12-24V DC, and can be programmed and monitored via the Arduino IDE platform. ARDBOX compact PLCs are available in two different versions with up to 20 I/Os giving a choice of digital, analogue and relay outputs. The M-DUINO series offers five different versions with up to 58 I/Os. All units support I<sup>2</sup>C communication allowing I/O expansion by connecting multiple units together. USB, RS232 and RS485 communication ports are also provided.



The panel PCs are open-source programmable 10.1-inch capacitive touchscreens, available in three different versions. HummTOUCH Android and HummTOUCH Linux give a choice of popular operating systems running on the Hummingboard ARM-based single-board computer. TOUCHBERRY Pi, based on the Raspberry Pi, runs the Raspbian Linux operating system. All the usual communication ports including Ethernet, USB, SPI Serial TTL and I<sup>2</sup>C are provided, and the units can be programmed via the USB port using the Arduino IDE.



## 4 x 4 mm GPS module for wearables & portables

Distributor Acal BFi has the Nano Spider from OriginGPS; the miniature module makes it possible for manufacturers to bring accurate GPS to tiny devices. Claimed as the world's smallest GPS module, Nano Spider is a fully integrated, sensitive GPS receiver module. Measuring 4.1 x 4.1 x 2.1 mm and with low power consumption, it is suitable for smart watches, wearable devices, trackers, and digital cameras. A double-sided circuit design reduces footprint size and makes the Nano Spider 47% smaller than previous solutions.

Offering accuracy of approximately one metre, the Nano Spider achieves a rapid time to first fix (TTFF) of less than one second, and tracking sensitivity of -163 dBm. The module achieves a state of near continuous availability by detecting changes in context, temperature and satellite signals.

By maintaining and opportunistically updating its internal fine time, frequency, and satellite data, the Nano Spider consumes micro-

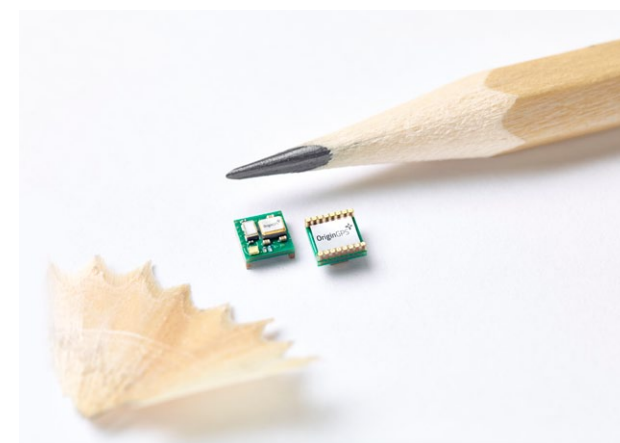

watts of battery power.

The module also features OriginGPS' proprietary Noise Free Zone (NFZ) system. Increasing noise immunity even under marginal signal conditions, it allows the module to provide high accuracy in dense urban areas, under thick foliage, or when the receiver rapidly changes position.





## FPGA development kit for high-bandwidth space & rad-hard applications

Offering it as the first radiation-tolerant FPGA for designers of space systems, Microsemi has introduced an evaluation and design platform, the RTG4 FPGA Development Kit. The kit provides space designers with an evaluation and development platform for applications such as data transmission, serial connectivity, bus interface and high-speed designs using Microsemi's RTG4 high-speed signal processing radiation-tolerant field programmable gate array (FPGA) device.

The development kit provides all necessary reference to evaluate and adopt RTG4 technology quickly, without the need to build a test board and assemble the device onto the board. It is applicable to remote sensing space payloads, radar and imaging, as well as spectrometry in civilian, scientific and commercial applications. Other applications include mobile satel-

lite services (MSS) communication satellites, as well as high altitude aviation, medical electronics and civilian nuclear power plant control.

"The extensive logic, memory, DSP blocks and IO capabilities of

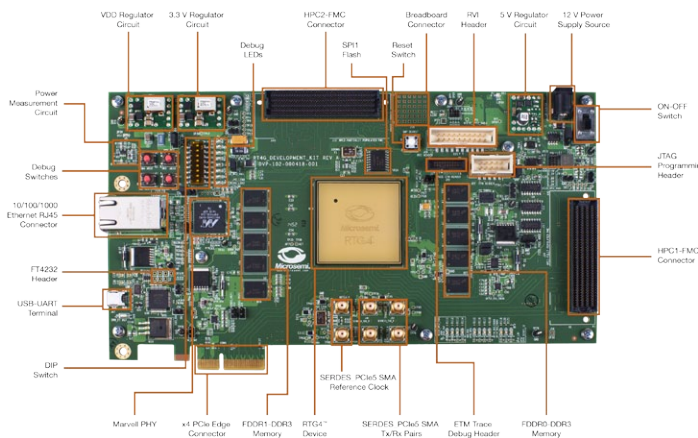

Microsemi's RTG4 FPGA with its inherent radiation tolerance and inbuilt configuration memory make this device perfect for spacecraft on-board applications," said Prof. Steve Parkes, managing director of U.K. space company, **STAR-Dundee**. "As a world leader in

SpaceWire network technology for spacecraft onboard data-handling, we took advantage of RTG4's embedded SpaceWire clock recovery circuits and high-speed SERDES capabilities to quickly demonstrate our flight-proven SpaceWire IP running at over 200 Mb/sec, and our next-generation SpaceFibre IP at 2.5 Gb/sec using Microsemi's RTG4 Development Kit."

RTG4 FPGAs are configured for modern satellite payloads. RTG4's reprogrammable flash technology offers complete immunity to radiation-induced configuration upsets in the harshest radiation environments, without the configuration scrubbing required with SRAM FPGA technology. RTG4 supports space applications requiring up to 150,000 logic elements and up to 300 MHz of system performance. RTG4 is Microsemi's latest development in a long history of radiation-tolerant FPGAs (formerly Actel branded) that are found in many NASA and international space programs.



## Comprehensive automotive Ethernet will enable secure autonomous vehicles - NXP

NXP has announced a complete automotive Ethernet product portfolio; its high-bandwidth technology will accelerate development of autonomous driving and secure connected vehicles, the company asserts.

The portfolio builds on BroadR-Reach – an automotive standard defined by the **OPEN Alliance** industry group, with the aim to make consumer-level Ethernet capable of meeting the automotive industry's stringent requirements. NXP is a founding member of OPEN Alliance and offers an automotive portfolio consisting of two product families, Ethernet transceivers (TJA1100) and Ethernet switches (SJA1105). Product samples are immediately available, and NXP's Ethernet transceivers will begin

production in Q4, 2015.

Ethernet is expected to provide the network backbone for autonomous driving and connected vehicles, as it is capable of the high data bandwidth, communications speed, weight reduction,

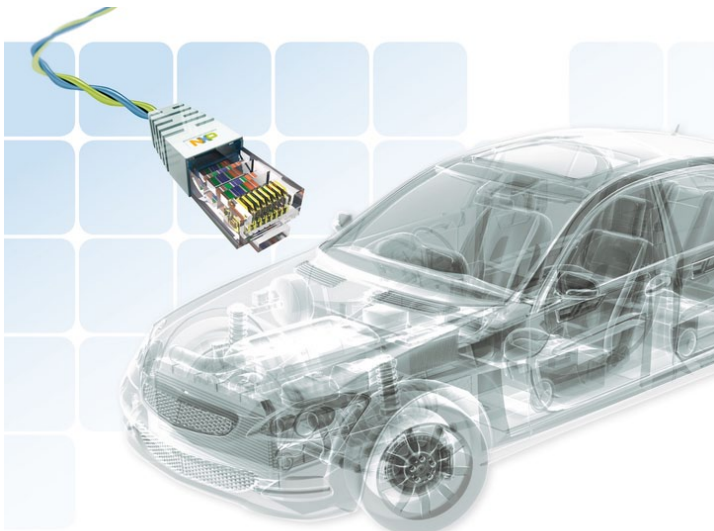

and cost efficiency that future connected cars require. NXP's modular approach with switch and transceiver is intended to allow for flexible and cost efficient combinations, enabling car makers to build optimal solutions for a wide range of networking architectures — from entry-level cars to high-end luxury vehicles. This will also

pave the way for new, distributed networking architectures (see NXP's [video](#)) in the future. The adoption of Ethernet, NXP contends, is quickly accelerating with the rise of secure connected cars and the subsequent high demands for data transport.

By developing technology purpose-built for automotive applications, NXP's Ethernet PHY TJA1100 supports automotive low power modes. When the engine is off, the systems sleep. Meanwhile, the Ethernet PHY stays partially powered, waking up the system only upon activity on the net-

work. In contrast to conventional solutions, the NXP Ethernet PHY does not require additional components such as voltage regulators to stay on while the engine is off, benefiting power consumption and battery lifetime.



## MEMS technology yields smallest, high sensitivity force sensor

ALPS has developed the “HSF-PAR Series” Force Sensor, for force sensing in input devices and

contain force sensors that are used to trace the trajectory of the pen tip, as well as to reproduce

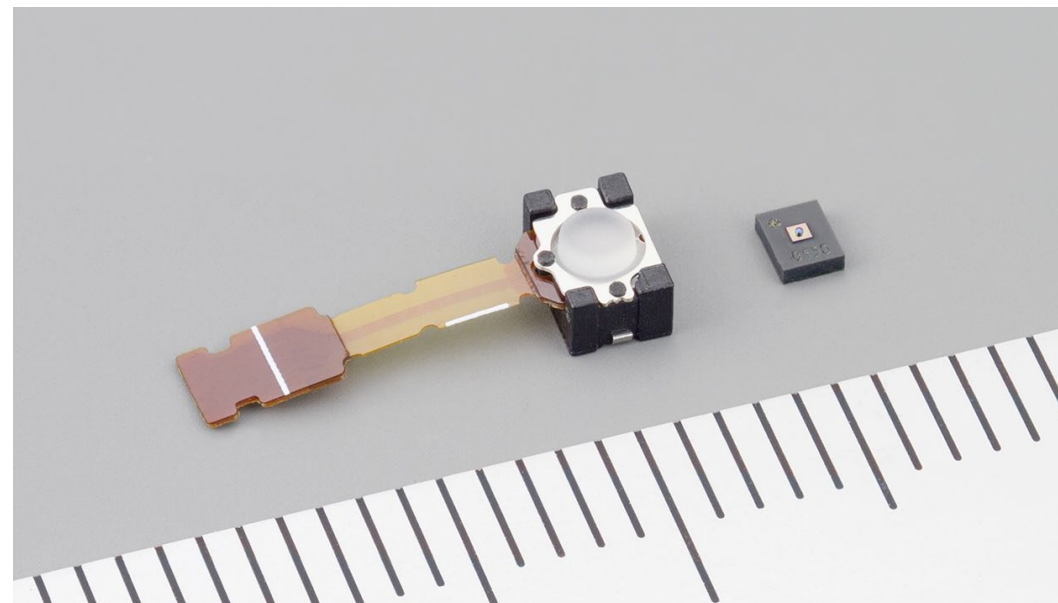

posture control in industrial equipment and robots, using MEMS technology to achieve the smallest size.

Demand for high-precision pen-shaped input devices (stylus pens) is growing, Alps says, with the rising popularity of digital drawing and painting. Stylus pens, or styli,

different thicknesses in the artwork corresponding to the pressure applied. To enable smoother tone transitions, however, styli require sensors with high resolution, leading to pen shafts that are too thick. Similarly, demand for compact, highly sensitive force sensors for applications such as load



detection on touch or contact, and load balance and grip strength control, is expected to rise.

Force sensors today (Alps notes) are generally either semiconductor strain gauge or metallic strain gauge types, and both have their issues. Semiconductor strain gauge force sensors offer high precision, but are large. Metallic strain gauge force sensors, on the other hand, can be made compact, though this comes with diminished sensitivity.

Responding to these issues, Alps has developed a versatile, high-precision force sensor, the HSFPAR Series. The force sensor was developed by applying to a semiconductor strain gauge original MEMS and packaging technologies built up over the years. Not only does the HSFPAR Series have compact, low-profile dimensions of 2.00 × 1.60 × 0.66 mm, the sensor can detect stress as low as 0.01N, enabling high-precision sensing of, for example, minor variations in pen pressure and load shift in robots.



## Netduino 3 for fast prototyping, in distribution

**D**istributor Mouser Electronics has the Netduino 3 platform, aimed at both quick-to-market commercial hardware solutions, and personal electronics projects, with maximum design flexibility and reduced risk. This newest version of the open-source Netduino platform includes, say its makers, the best of the features that made previous versions popular, with added Wi-Fi connectivity.

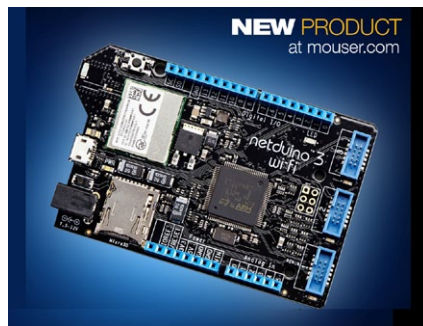

Netduino 3 is an open-source electronics platform designed around the Microsoft .NET Micro Framework, combining the ease of high-level coding and the raw feature set of the STM32 F4 family of microcontrollers. The 32-bit ST microcontroller on the Netduino 3 has a 168 MHz ARM Cortex-M4 processor with 2 MBytes of dual-bank, read-while-write flash memory and up to 256 kBytes of SRAM, including 64 kBytes

of core-coupled memory (CCM). The Netduino 3 WiFi board supports 802.11b/g/n (2.4 GHz) Wi-Fi across open networks as well as through WEP and WPA2 protocols, and includes support for SSL 3.0 security, including TLS

1.2. The Netduino 3 Ethernet board features a 10/100 Mbps Ethernet port.

Like Netduino 2, this version features Arduino-compatible headers, including 22 GPIO pins with

SPI, I<sup>2</sup>C, four UARTs (one RTS/CTS), and six PWM channels as well as six 12-bit analogue-to-digital converter (ADC) channels. The board also boasts three GoBus 2.0 ports for additional plug-and-play capabilities and a microSD slot for up to 2 GBytes of storage. Netduino 3 also includes upgradable firmware for increased functionality in the future.



## Twin approaches to high-density flash, from Toshiba

**I**n two closely-spaced announcements, Toshiba has described two alternative methods of producing high-density packaging for flash memory. In the first, the company outlines a methodology to pack 256 Gbits of flash on a (monolithic) chip, in 48-layer 3D structure. This is the latest generation of its BiCS FLASH, three-dimensional (3D) stacked cell structure flash memory. Toshiba claims a record with the first 256-Gigabit 48-layer BiCS FLASH device, which uses three-bit-per-cell (triple-level coding or TLC).

BiCS FLASH uses a 48-layer stacking process to exceed the capacity of mainstream two-dimensional NAND flash memory, while (Toshiba asserts) enhancing write/erase reliability endurance and boosting write speeds. The 256 Gb device is suited for typical NAND-flash applications, including consumer SSDs, smartphones,

tablets, memory cards, and enterprise SSDs for data centres.

In the second technology, Toshiba stacks 16 (separate) NAND Flash dice with TSV technology; the corporation has announced the development of a 16-die (maximum) stacked NAND flash memory using Through Silicon Via (TSV) technology, yielding a capacity, in the generation of dice used in the prototype, of 256 Gb.

TSV technology has been explored for many years as an alternative to wire bonding (on their edges) of silicon dice placed one on top of another. Silicon from thinned wafers has vias 'drilled' completely through, which are then filled with metal to provide connectivity from the diffused side to the back side of the die. Dice of the same dimensions can be stacked, whereas with wire bonding a pyramidal stack is needed to gain access to each die's periphery. Toshiba's announcement indicates it has overcome the challenges of producing multi-die stacks in this way.

TSV technology's use of vertical electrodes and vias to pass through the silicon dice enables, Toshiba says, high-speed data input and output, and reduces power consumption. Toshiba's TSV technology achieves an I/O data rate of over 1 Gbps which it says is higher than any other NAND flash memories with a low voltage supply: 1.8V to the core circuits and 1.2V to the I/O circuits and approximately 50%

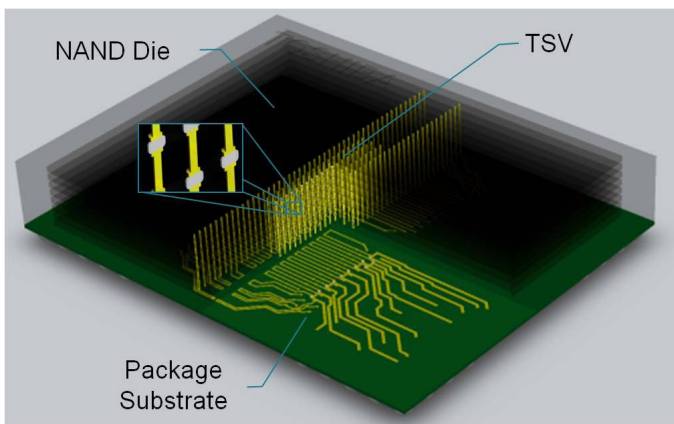

power reduction (compared to the company's current flash product) of write operations, read operations, and I/O data transfers.

Asked to clarify when these technologies will be placed into production, Toshiba responded that in the BiCS technology, a 128 Gbit MLC CS variant will be produced from September 2015; and a 256 Gbit TLC (triple-level-cell) MP product towards the end of 2015. The company also clarified that while the TSV technology will be available in approximately the same timescale, it is viewed as an alternative means of realising die stacking; in this context, wire bonding will remain the standard technology. TSV offers a technique to realise the highest speeds and lowest power; a high quality, but also high cost, option; wire-bonded production remains the standard construction, with lower costs.

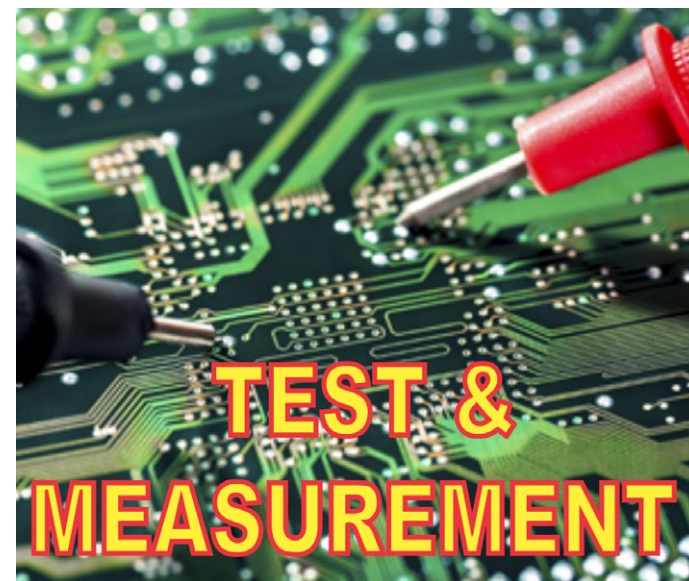



## HIGHER LINEARITY IN RF/IF AMPS EASES DESIGN CHALLENGES

BY GREG FUNG, LINEAR TECHNOLOGY

Our communication infrastructure's limited bandwidth is increasingly filled by our increasing thirst for data of all types. Communications architects define systems that pack increasingly more data into limited bandwidth, but data rate improvements come at a price: the need for increasingly higher fidelity transmit and receive signal chains.

When it comes to amplifiers, low noise and high linearity are required to faithfully reproduce a signal without degradation. At low signal powers, undesired noise must be low enough to allow the intended signal to rise above the noise floor. At high signal levels, a linear amplifier must prevent unwanted harmonics and intermodulation products from masking the intended signal.

Recent introductions include fixed gain amplifiers that achieve the combination of very high OIP3 (linearity) with very low associated noise. OIP3 figures of 47 dBm/50 dBm at 240 MHz ease implementation challenges and guarantee performance in application circuits. The LTC6431-15 is a single-ended radio frequency (RF)/intermediate frequency (IF) gain block that can directly drive a 50Ω load, whereas the

LTC6430-15 is a differential RF/IF gain block with higher power and an even wider linear bandwidth. This mix of features eliminates implementation difficulties by internally handling biasing, impedance matching, temperature compensation and stability.

### Low NF for low input signals

Noise limits communication system sensitivity at low input signal levels. Noise in a communication system is characterised by the noise figure (NF), which is the signal-to-noise power ratio at the input divided by the signal-to-noise power ratio at the output, expressed in decibels. There is always noise at the input of an amplifier and it is amplified along with desired signal. The NF is an indicator of how much unwanted noise the amplifier itself adds to the signal. Ideally, the amplifier would have a NF of 0 dB, but any real amplifier adds noise, so the goal is to minimise noise impairment. Typical IF amplifiers have noise figures of 3 dB to 12 dB. The newer designs described here both exhibit a 3.3 dB NF at 240 MHz.

### Low OIP3 minimises IM products

Linearity limits the ability to isolate the desired signal from unwanted signals in the frequency

domain. At high input signal levels, the desired signal rises far above the noise floor, so noise is less of an issue, but an amplifier's linearity becomes increasingly important.

For instance, if a single tone is injected (Figure 1) into a nonlinear amplifier, the result is the desired tone plus its harmonics. Normally, these harmonics can be filtered out, as they are far enough away in frequency from the desired tone. If two tones are injected (Figure 2) into a nonlinear amplifier, the result is a far more complicated mix of the two desired tones and a multitude of unwanted tones, including harmonics of the two tones, the sum and difference of the two input tones, and other intermodulation products.

Intermodulation (IM3) products ( $2f_1 - f_2$  and  $2f_2 - f_1$ ) are a subset of these unwanted tones and they are particularly troublesome. IM3 products can fall very close to the intended signal's frequency, making them nearly impossible to filter out.

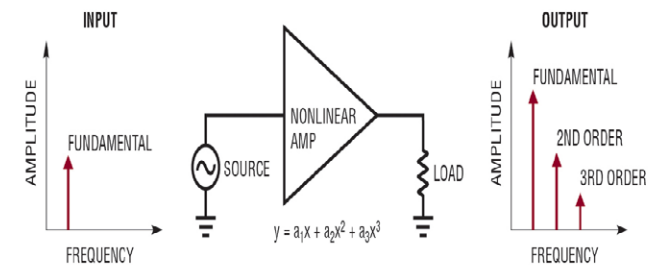

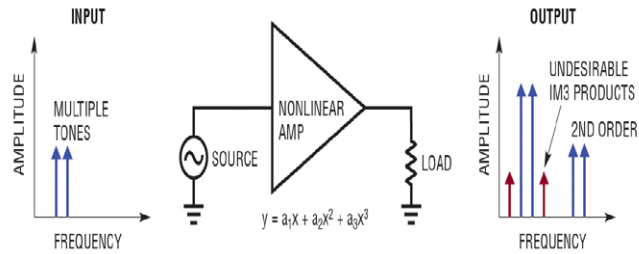

Amplifier linearity is most often characterised by the 3rd order output intercept point (OIP3)—the hypothetical point where the power of the IM3 products intersects the fundamental power (Figure 3). The LTC6431-15 exhibits very small IM3 products and thus its OIP3 is very good. Minimising the IM3 product is especially important when a blocker (interferer) or an adjacent channel is nearby. Figure 3 shows that IM3 products grow three times faster than the desired tones. This limits the acceptable output power, and therefore the input power, that the amplifier can handle without distorting the desired signal.

Noise (characterised by NF) limits an amplifier's sensitivity at low input signal amplitudes, while linearity (characterised by OIP3) limits sensitivity at high input amplitudes. Taken together, these two metrics, NF and OIP3, define the amplifier's useful dynamic range for a signal.

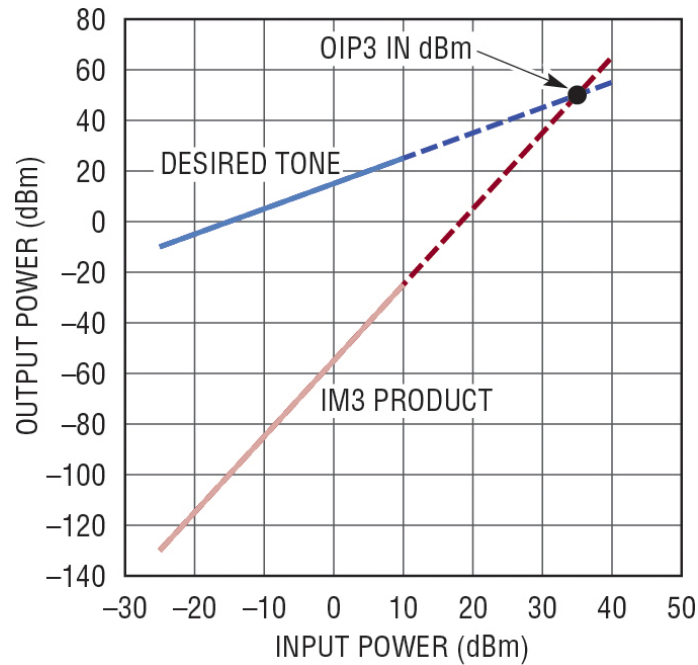

**Figure 3** Output 3rd order intercept point (OIP3)

## Linearity eases difficult communication problems

The LTC6431-15 quotes a typical OIP3 of 47 dBm at 240 MHz—essentially pushing IM3 products into the noise floor so that they don't interfere with the intended signals (Figure 4). Its companion part has an OIP3 of 50 dBm at 240 MHz. Both amplifiers offer a very wide dy-

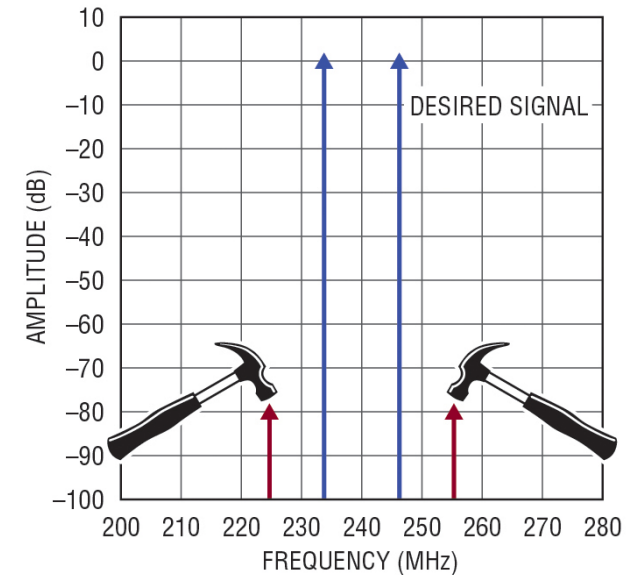

**Figure 4** The LTC6431-15 has an OIP3 of 47 dBm at 240 MHz—essentially pushing the IM3 products of a 2-tone signal into the noise floor so that they don't interfere with the intended signals.

amic range when combined with their 3.3 dB NFs—addressing the high data rate challenge by maintaining high fidelity at both high and low signal levels.

*The article continues by considering biasing and matching arrangements with – and within – the integrated RF amplifiers. Click for pdf.*



**Download PDF  
of Article**



**Find RF/IF AMPS  
on EETsearch**



# “POWER POINTS”

## NEW HORIZONS SPACECRAFT'S POWER ISSUES MAKE YOURS LOOK TRIVIAL

BY BILL SCHWEBER, EDN

Nearly all engineers deal with power issues. Regardless of whether the concerns are focused on getting it, managing it, using it, or disposing of it as related to run time, battery life, recharge cycles, thermal dissipation, or regulatory efficiency and PFC mandates, power issues are unavoidable.

Even with all these headaches, it's worth stepping back for perspective on the severity of your problems. One way to do that is to look at the New Horizons spacecraft which recently flew past dwarf planet Pluto, taking photos and collecting scientific data (Figure 1). We've been dazzled by it, amazed by it, and in turn, admired its truly astounding scope and complexity. The planning, execution, and significance of this effort, along with the thousands of people behind it at all levels, and the technologies that made it possible are truly impressive. (Similar congratulations and respect must also go to the team at the [European Space Agency](#) for their just completed successful [Rosetta orbiter/Philae lander](#) mission to comet 67P/Churyumov-Gerasimenko.)

With this mission's 10-year travel time, billion-mile distance, and remoteness-induced latency, many "power" concerns played a big

role in achieving success. I did some browsing at the [NASA New Horizons](#) site, as well as the [Johns Hopkins Applied Physics Laboratory](#); they are responsible for mission management and development as well as spacecraft integration and operations, with the full, interesting list of their management and technical partners here).

What I found when reading about the power subsystem within the system block diagram (Figure 2) gave me further respect for the project team challenge and accomplishments.

Among the facts I found were these:

- Basic power for the spacecraft comes from radioisotope thermoelectric generator (RTG, a type of thermoelectric generator or TEG)

with 11 kilograms (24 pounds) of plutonium dioxide as its core energy source.

- The RTG produced almost 4 kW of thermal power at launch, while its electrical output was approximately 245W@30 VDC. (This is indicative of one downside of RTGs and TEGs: they are fairly inefficient. But when you need them for their virtues, you live with the downside.)

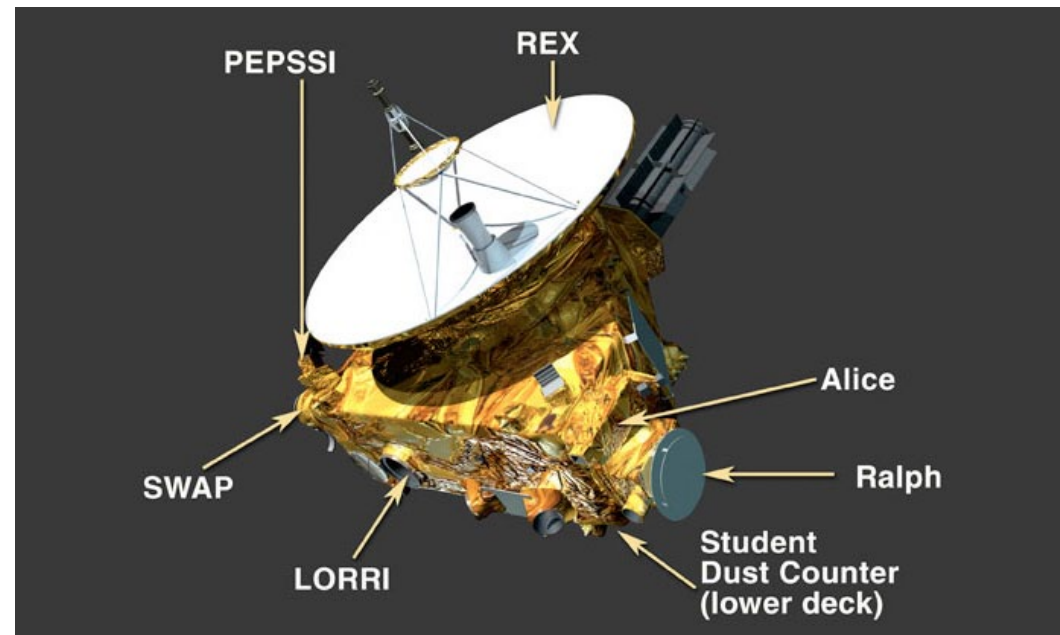

Figure 1. The New Horizons spacecraft, in an artist rendering of its approach to Pluto; the RTG is the greyish cylinder on the right, just below the dish antenna.





# EMBEDDED SYSTEM DEBUG

## IT'S NOT A FEATURE, IT'S A BUG...

BY JOHAN KRAFT, PERCEPIO AB

Anyone involved with software development will have most likely heard (and perhaps even said) the phrase 'it's not a bug, it's a feature' at some point, and while its origins remain a mystery, its sentiment is clear; it's a bug that we haven't seen before.

Intermittent 'features' in an embedded system can originate in either the software or hardware domain, often only evident when certain conditions collide in both.

In the hardware domains, the timings involved may be parts of a nano second: where the logic is accessible, such as an address line or data bus, there exist instruments that can operate at sufficiently high sample rates, allowing engineers to visualise and verify such 'glitches'. In the software domain this becomes much more challenging.

### Sequential processing

While parallel processing is being rapidly adopted across all applications, single-processor systems remain common in embedded systems, thanks partly to the continued increases in the performance of microcontroller cores. Embedded MCUs are now capable of executing a range of increasingly sophisticated Real-Time Operating Systems, often including the ability to run various communication protocols for both wired and wireless interfaces.

Whether in a single- or multi-processing system, combining these tasks with the embedded system's main application, written by the engineering team, can make embedded software builds large, com-

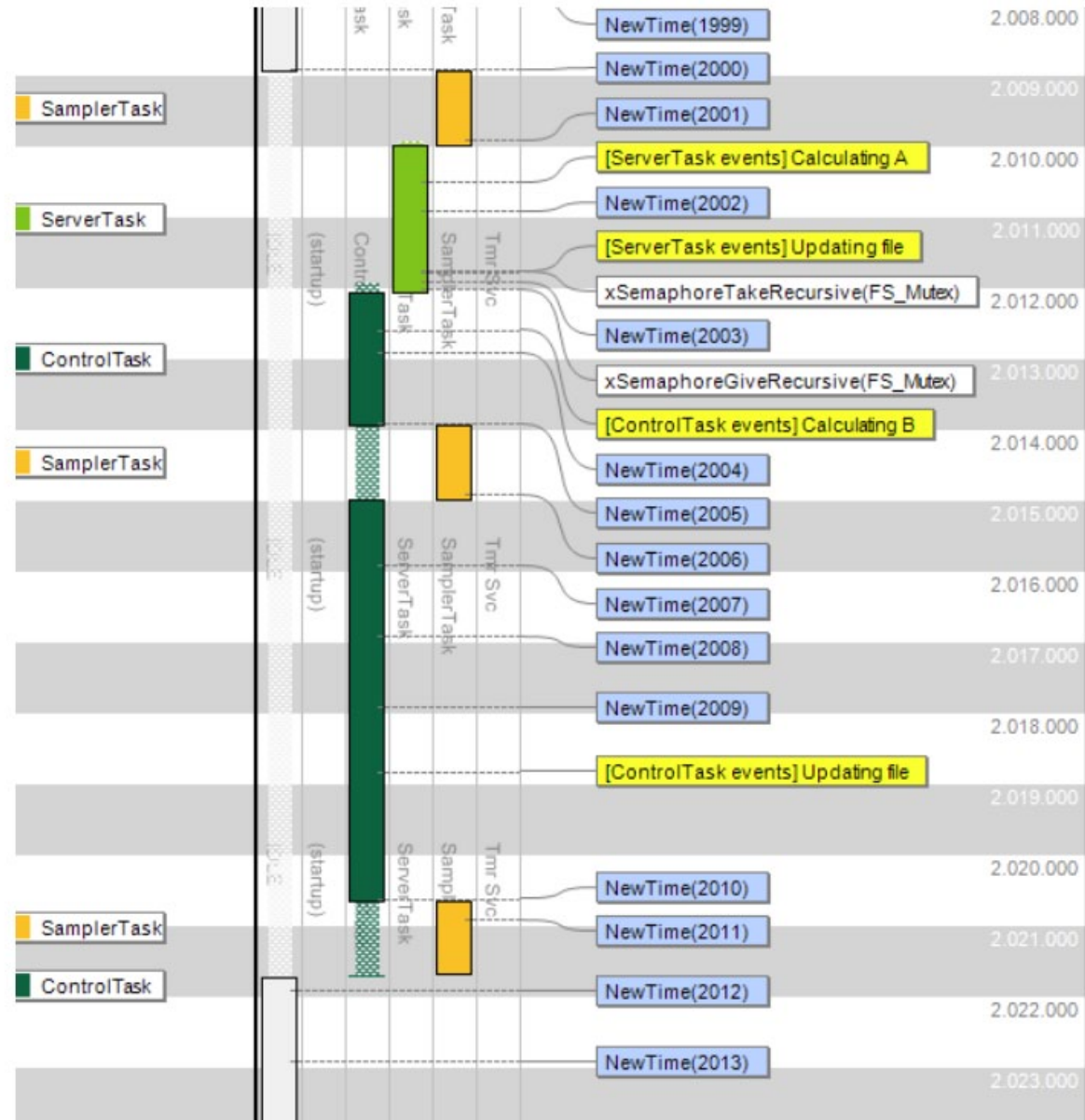

# EMBEDDED SYSTEM DEBUG

plex and difficult to fault-find, particularly when visibility into the code's execution is limited. It can also lead to the dreaded intermittent fault which, if part of the system's operation is 'hidden', can make solving them even more challenging.

A typical example may be an unexplained delay in a scheduled task. Of course, an RTOS is intended to guarantee specific tasks happen at specific times but this can be dependent on the task's priority and what else may be happening at any particular time. In one real-world example, where a sensor needed to be sampled every 5 msec, it was found that occasionally the delay between samples reached 6.5 msec, with no simple explanation as to the cause. In another example, a customer reported that their system exhibited random resets; the suspected cause was that the watchdog was expiring before it was serviced, but how could this be checked? In yet another example, a system running a TCP/IP stack showed slower response times to network requests after minor changes in the code, for no obvious reason.

These are typical examples of how embedded systems running complex software can

behave in unforeseen ways, leaving engineering teams speculating on the causes and attempting to solve the problems with only empirical results from which to assess their efforts. In the case of intermittent faults or system performance fluctuations, this is clearly an inefficient and unreliable development method.

## Trace tools

The use of logging software embedded in a build in order to record certain actions isn't new, of course, and it can offer a significantly improved level of visibility into a system. However, while the data generated by such trace software is undoubtedly valuable, exploiting that value isn't always simple. This is where a new generation of visualisation tools, optimised for – and with comprehension of – embedded application code, can deliver added value. The main view presented by the visualisation tool is a vertical timeline visualising the execution of tasks/threads and interrupts (Figure). A series of different graphical views are able to show different aspects of the software's execution that are unavailable, or difficult to interpret, with debuggers alone... *the article continues by giving some examples of how the visualisation approach aids the debug process; click for pdf*



Download PDF  
of Article



Find embedded software development tools  
on EETsearch



# POWER CONVERSION

## NON-ISOLATED OFFLINE QUASI-RESONANT FLYBACK CONVERTER

BY FLORIAN MUELLER, TEXAS INSTRUMENTS

This article presents a non-isolated offline quasi-resonant (QR) flyback converter design, including practical tips for a well optimised design. The reference design uses a QR flyback controller to generate a 22V/3.5A output from an AC input source. This flyback converter is not isolated: three transistors are used in place of an optocoupler to reduce the overall BOM cost.

### Principles of quasi-resonant operation

The difference between a QR flyback and a traditional flyback is that the resonance ringing, caused by the circuit parasitics, is used to reduce the switching losses. QR flybacks always work in discontinuous conduction mode or boundary mode. After the core has demagnetised, no energy is left in the transformer but there is still energy in the parasitic switch-node capacitance. This energy, and the primary inductance, generate a resonance ringing. Modern QR flyback controllers monitor the voltage of the switch-node and switch directly at the resonant valley where the drain-to-source voltage is lowest and the switching losses are reduced. Another advantage of the valley switching is that the EMI will be reduced.

### Design tips

The circuit of a QR flyback converter consists of four blocks (Figure 1: non-isolated quasi-resonant flyback converter) namely the input filter, the powerstage, the controller and the compensation circuit. Some practical hints are given below for each block.

### Input filter

Usually, a common mode (CM) and a differential mode (DM) filter are employed for an offline design delivering an output power higher than

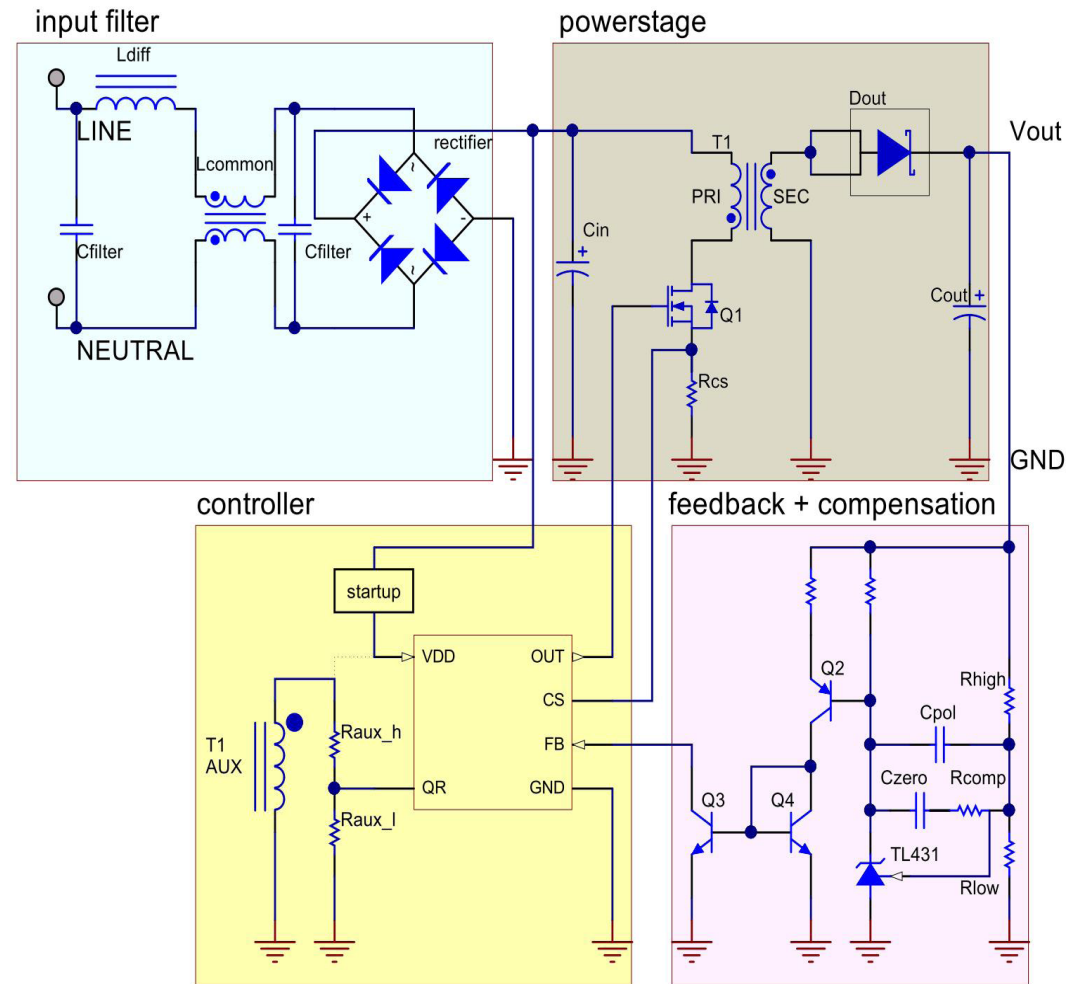

Figure 1. Non-isolated quasi-resonant flyback converter

# POWER CONVERSION

10W. Differential mode noise is produced by normal switching actions due to the input current. It appears between the L (live) and the N (neutral) AC supply lines. Common mode noise appears on both supply lines at the same time, with respect to the ground plane. The high switch-node voltage, fast switching edges and the parasitic coupling capacitances introduce currents into the local ground plane. This injected current is measured as a noise voltage by using a 50Ω shunt in a LISN (line impedance stabilisation network). To meet the international regulation limits this noise must be attenuated by a CM filter. The CM filter consists of a CM choke and a Y-capacitor connected between the primary ground and the secondary ground for an isolated design. Unfortunately the safety regulation limits the maximum ground leakage current and therefore the maximum value of the Y-capacitor, which makes the filter design more challenging. The PMP10121 (the design discussed here is in TI's Power reference design series: all design documents such as BOM, test report and schematic can be downloaded at [www.ti.com/tool/pmp10121](http://www.ti.com/tool/pmp10121)) is a non-isolated design, so the primary and secondary grounds are connected together. The advantage is that there is no Y-capacitor and a smaller CM induc-

tor is sufficient to meet the regulatory limit.

## Power stage

The most important component of the QR flyback converter is the transformer. Besides the operating voltages and currents, it also defines the operating modes and the switching frequency range. There are two kinds of QR flyback converter. Both monitor the switching waveform for valley switching, but they use different modulation methods to achieve a regulated output voltage. Some of the controllers (such as LM5023, UCC28600) modulate the switching frequency and the primary peak current at the same time, over a wide operating range. Therefore, it is possible to operate at quasi-resonant-mode over a wide input voltage range and output power range. Quasi-resonant-mode means switching at the first valley. This leads to best possible efficiency and best EMI behaviour. The other kind of controller modulates the switching frequency or the primary peak current: but not at the same time

*The article continues by considering in turn the transformer design, compensation and feedback and the controller itself. Click for pdf.*



## LEDLighting



Download PDF  
of Article



Find quasi-resonant flyback converter  
on EETsearch



# Analog Tips

## SFDR FOR ADCS

BY IAN BEAVERS, ANALOG DEVICES

The performance of the analogue-to-digital converter (ADC) determines how well weak signals can be extracted from the background noise in signal-acquisition applications ranging from radar to telecommunication systems.

Spurious-free dynamic range (SFDR), which represents the smallest power signal that can be distinguished from a large interfering signal, defines the dynamic ratio between the root-mean-square (rms) value of the carrier power and the rms value of the next most significant spurious signal, harmonic, or noise seen in the frequency domain. The ADC data sheet specifies SFDR at the given conditions.

Nonlinearities, inherent to all ADCs, create harmonic distortion in any signal. Harmonics are multiples of the fundamental frequency that typically limit the ADC's SFDR. Symmetrical nonlinearities seen at an ADC input cause odd-ordered harmonics. Asymmetri-

cal or single-sided nonlinearities cause even-ordered harmonics. To avoid aliasing, the sampling frequency ( $f_s$ ) must be at least twice the highest frequency of interest. The Nyquist frequency is important for spectral planning purposes, as higher frequencies, and harmonics at multiples of the fundamental frequency, will fold back into the band of interest (as illustrated in the diagram), interfering with the signal. Therefore, it is important to plan the sample rate and frequency band of ADC observation to avoid harmonic aliasing that limits SFDR.

Figure 1. SFDR within a Nyquist rate ADC is defined by the dynamic range from the fundamental carrier to the largest harmonic, noise, or spur. Harmonics can fold back around the Nyquist rate, as shown.

GSPS (Gigasample/sec) ADCs sometimes employ an interleaving scheme to achieve the full high-speed data rate, using two or more cores. While one channel

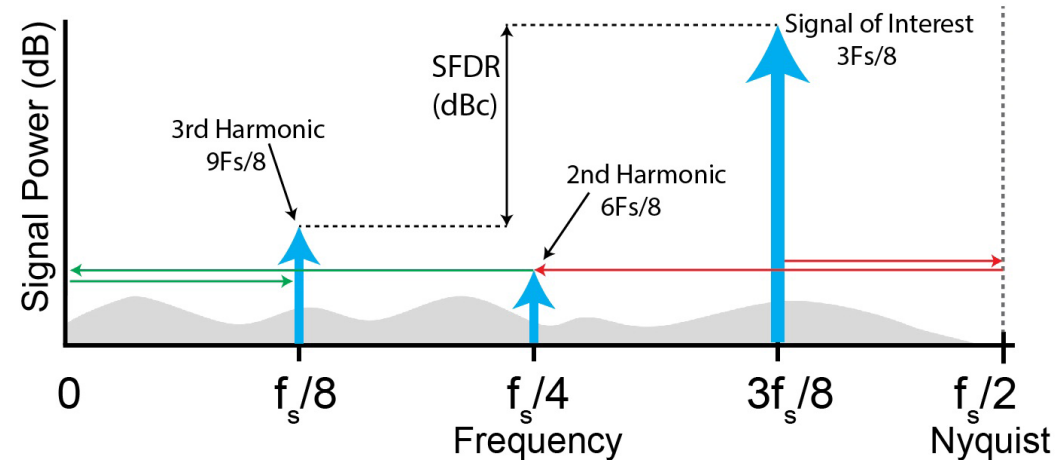

**Figure 1.** SFDR within a Nyquist rate ADC is defined by the dynamic range from the fundamental carrier to the largest harmonic, noise, or spur. Harmonics can fold back around the Nyquist rate, as shown.

is sampling, the other(s) would be processing. A dual-channel ADC could “ping-pong” between the cores to achieve the full data rate, but this exposes slight differences in phase, offset, gain, and bandwidth between the cores. As a result, new interleaving artifacts and spurs can be introduced into the

frequency spectrum, also reducing the SFDR.

ADC architectures that use only one processing core will not exhibit interleaving spurs. For example, a wideband ADC with a single pipeline will tout a relatively high SFDR, typically limited by the second or third harmonic.

**Ian Beavers** [ian.beavers@analog.com], a staff engineer for the Digital Video Processing Group at Analog Devices (Greensboro, NC), is a team leader for HDMI and other video interface products. With over 15 years' experience in the semiconductor industry, he has worked for ADI since 1999. He holds a bachelor's degree in electrical engineering from North Carolina State University and an MBA from the University of North Carolina at Greensboro.

# EMBEDDED BASICS

## 7 TIPS FOR DEBUGGING EMBEDDED SOFTWARE

BY JACOB BENINGO, FOR EDN

**D**ebugging is one task every developer wants to avoid but it is unfortunately a necessary evil of software development. In fact, as [EDN's Embedded Study](#) revealed, embedded development projects on average spend more than 20% of their total effort on debugging alone. When the time comes to roll-up your sleeves and start a debugging session, here are some tips to help you along.

**Tip #1 – Take controlled baby steps:** When a bug creeps into embedded software, the developer's first instinct is often to jump into the code and start making changes. Instead of making changes in a controlled and directed manner, though, the developer's approach is usually haphazard and nearly random. Embedded software development isn't the Wild West. The resolution of even the simplest bugs should involve reviewing available data, evaluating it, hypothesising the most likely cause, updating the code, and then testing the update. In the event that the change does not solve the problem new data should at least come to light, which then helps the process to be repeated.

**Tip #2 – Increase assertion density:** The ASSERT macro is a great tool that returns an

error message at runtime if the asserted condition is false. Developers can use this macro to verify that assumptions within their code are holding true. Surprisingly, many developers don't take the time to put assertions into their code. The ASSERT density of a code base can often be the difference between long and painful debug sessions or the trapping of a failed assumption the moment it happens. ASSERT can help a developer discover bugs or assumption failure immediately. What is the ASSERT density of your code base?



**Tip #3 – Use a data logger:** Information about how the software is operating is the greatest tool an embedded software engineer can

have when debugging. Having performance information such as when tasks start and complete, whether they are preempted, and similar details, can be critical. A log of actions taken is a great way for a developer to gain insight into the software's behaviour. A log can be as simple as a RAM buffer, a file written to external flash, or as complex as encoded data transmitted to a remote location.

**Tip #4 – Use advanced breakpoints:** Developers are familiar with using standard breakpoints that can be turned on in an IDE by simply double clicking on a line of code's left margin. However, many IDEs also have far more advanced breakpoint capabilities, ones that developers rarely utilise. An example of an advanced break point is setting a line to break when a variable reaches a certain value. The use of advanced break points can drastically decrease debugging time and make difficult to catch bugs far easier to spot.

**Tip #5 – Review the datasheets again:** Debugging peripherals can be especially difficult. Modern microcontrollers can have dozens of registers involved in setting up a single peripheral, and these peripheral settings are not always obvious or well documented. Even worse, the details on how to properly set the



# EMBEDDED SYSTEMS



peripheral up are usually not all within a single datasheet. Instead, the information is in the form of "bread crumbs" scattered amongst the family and peripheral datasheets, and sometimes even in application notes. Looking at just one document is not enough. When hardware is misbehaving, you'll need to review the datasheets again and again.

**Tip #6 – Monitor the call stack:** Developers

will sometimes question how they ever got to a specific line of code in the first place. IDEs contain a call stack window that can reveal exactly that information. The call stack shows what functions were called and in what order, revealing information that can be very useful for tracing a bug.

**Tip #7 – Take a break:** Debugging can be a taxing exercise. Diving deep into the workings

of software and hardware can give a developer tunnel vision. A developer sometimes needs to step back by either moving on to a different task or by taking a break. Getting away from the system by going for a walk or doing something relaxing will allow the subconscious mind to work on the solution while the conscious mind rests, so that when it's time to start looking at the code again, additional insights will usually follow.

Whether you spend a lot of time debugging or very little, the fact is as embedded software developers it is impossible to avoid. Using the tips in this article can help make debugging more successful, and thus a little bit more palatable.

**Jacob Beningo** is a Certified Software Development Professional (CSDP) whose expertise is in embedded software. Feel free to contact him at [jacob@beningo.com](mailto:jacob@beningo.com), at his website

[www.beningo.com](http://www.beningo.com), and sign-up for his monthly Embedded Bytes Newsletter.



# LOW-COST DESIGN TOOLS

## DESIGNING WITH DESIGNSPARK TOOLS

BY PETE WOOD, RS COMPONENTS

**P**ete Wood, DesignSpark Community Manager at RS Components discusses some of the capabilities and advantages of the DesignSpark board-layout and 3D modelling tools, while looking at a selection of applications that have benefitted from use of the tools.

The availability of free and downloadable design tools in conjunction with the rise of electronic engineering design and development communities has been a key enabler for wider collaboration among engineers. The entry into this arena from RS Components has been the DesignSpark ecosystem, launched in 2010, offering online design resources and free downloadable tools including DesignSpark PCB, which is a professional-grade schematic-capture and PCB design tool, and DesignSpark Mechanical, an advanced 3D CAD tool based on direct modelling techniques. DesignSpark also offers a huge library of PCB schematics, components footprints and 3D models, as well as an area for collaborating on ideas and designs.

### PCB Design

Launched at the same time as the DesignSpark

ecosystem, DesignSpark PCB has further expanded the possibilities for new users to do quite simple but powerful electronic designs. Importantly, the software is also being used in the professional design process as an augmentation to commercial CAD tools. Rapid turn-around prototyping has been the driving force as the tool is easy to use and means engineers can very quickly create a concept design. The software also has the ability to provide a rough Bill-of-Materials cost – via pricing information on [specific to] the RS site – and obtain a quote for prototyping from a partner PCB manufacturer.

DesignSpark PCB can accept export files from other free PCB design tools and has also received backing from leading semiconductor manufacturers with many training their field applications teams to help customers create designs with the tool. Use of a freely available platform can also enable greater collaboration and sharing of designs and further enable the growing open-hardware movement. For example, DesignSpark PCB was used in the development of one of the early printers from the [RepRap](#) open-source self-replicating 3D printing project: specifically, the design of the



**Figure 1.** *The Pi-Top build-it-yourself laptop*

control board used in the Mendel printer. A more recent open-source hardware application for DesignSpark PCB was its use in the development of the crowd-funding Pi-Top build-it-yourself Raspberry Pi laptop kit. The Pi-Top has been designed to help people understand electronics better and create hardware including PCBs and the printing of 3D objects.

A major challenge for the Pi-Top developers was enabling the Raspberry Pi to use a 13.3in high-definition laptop screen. The first Pi-Top design used an LVDS (low-voltage differential signalling) screen as these were widely avail-



# LOW-COST DESIGN TOOLS

able and also have relatively easy interfacing. DesignSpark PCB was used to design an HDMI-to-LVDS bridge to output the video signal from the Raspberry Pi. However, in subsequent designs it was decided to change to the eDP (embedded DisplayPort) format as it offers several advantages over LVDS, such as coming with AUX channels (for automatic resolution/format settings), lower EMI and lower

pin count. In addition, the long-term availability of eDP screens is higher, as most notebook manufacturers are making the transition to eDP due to its many advantages.

*This article continues with further details of the Pi-Top project, the associated mechanical CAD software, 3D-printed prototyping, and its extension to 2-D part drawing and prototyping.*

## Electrical design tool added to free CAD portfolio

As this issue was being prepared, DesignSpark Electrical was disclosed as the latest free software package to be made available in this offering. The tool brings time-saving and error-reduction benefits to electrical system design, RS says.

In electrical design, there are many engineers who have not had the productivity gains taken for granted in, for example, the PCB design sector – RS asserts. Perhaps the majority of engineers still work with paper design, or very general-purpose drawing/planning software. DesignSpark Electrical is a fully specified electrical CAD package with key benefits, to deliver time saving and error avoidance, for control panel, machinery and electrical system design. Among other benefits, it offers a wiring-based approach – wiring line diagrams – to system planning that is familiar to electronic and PCB engineers. From a connectivity base, engineers can call real components from a library, complete connectivity with automatic wire numbering (maintained through changes), and proceed to populate cabinets, with assistance in making the optimum choice in terms of cabinet size and similar parameters. Read more about this extension to the distributor's software suite [here](#).



Download PDF  
of Article



Find DesignSpark board-layout tools  
on EETsearch

# designideas



- AC power measurement uses PWM & PAM
- Fast, low-noise JFET amp is stable over temperature

### AC power measurement uses PWM & PAM By Adolfo Mondragon



Measurement of average power in a 60 Hz circuit (equivalent to  $V_{RMS} \times I_{RMS} \times \cos(\phi)$ ) can be done by sampling the product of voltage and current and averaging. This requires four quadrant multiplication since the instantaneous voltage and current can have opposite polarities. It can be accomplished by a number of means, including analogue to digital (A/D) conversion followed by digital signal processing, or by using a relatively expensive analogue multiplier chip followed by analogue or digital processing. This Design Idea presents a third approach. It uses inexpensive op-amps and an analogue switch to implement a pulse width/pulse amplitude modulator (PWM/PAM) used as a four quadrant multiplier. This circuit can be adapted to many different applications.

The basic concept of a PWM/PAM multiplier is that the average value of a (non-overlapping) pulse waveform over a single cycle is the area of the pulse divided by the pulse repetition period. With each rectangular pulse amplitude proportional to voltage, and width proportional to current, the area of the rectangle is proportional to the product: voltage times current. If the pulse repetition rate is much higher than the frequency being measured, it can be assumed that the voltage and current do not change

appreciably during one cycle of the pulse waveform. The PWM/PAM output is followed by a low-pass filter to remove the pulse frequency and its harmonics and recover the desired average.

The circuit uses two transformers: a step-down transformer TR1 to produce a low-level voltage signal, and a current transformer TR2 to produce a low-level current signal with full galvanic isolation.

Op-amp IC1-A acts as a comparator and generates a fairly linear triangular waveform (Figure 2) with a frequency of about 6 kHz. This oversampling (100 times the 60 Hz signal frequency, or 50 times the theoretical Nyquist rate) is required to achieve an error below 1% of full scale. The triangle wave peak-to-peak amplitude must meet two criteria for an acceptably linear response. First, it

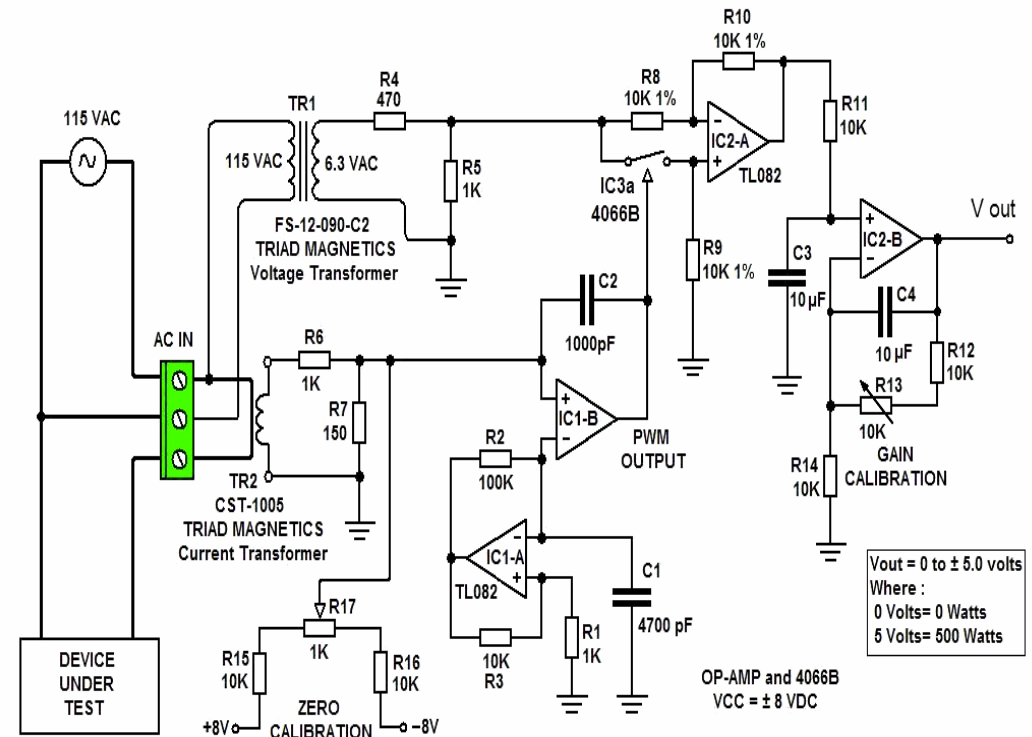

Figure 1. Measure AC power using pulse modulation techniques

must be greater than or equal to the AC current maximum peak-to-peak voltage from T2 so that a 100% PWM duty cycle is possible. Second, it must be at least 10% less than  $\pm V_{CC}$ .

Op-amp IC1-B is configured to generate



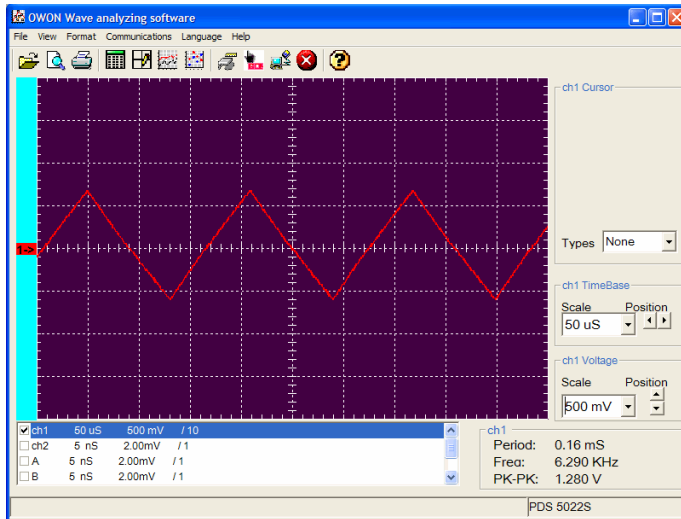

Figure 2. IC1-B (-) input

a zero-baseline bipolar square wave (Figure 3) with duty cycle determined by the instantaneous value of the current signal from T2. Capacitor C2 is required to obtain sharp output voltage transitions. The op-amps should be capable of a slew rate of 10 V/ $\mu$ sec or more to produce an optimal square PWM signal. When the instantaneous value of the current signal from T2 is zero, the duty cycle at IC1-B's output will be 50%. As the current signal increases from zero to full scale, the duty cycle increases from 50% to 100%. As the current signal decreases from zero to negative full scale, the duty cycle decreases from 50% to 0%.

Op amp IC2-A, switch IC3-A, and the associated resistors implement a four-quadrant

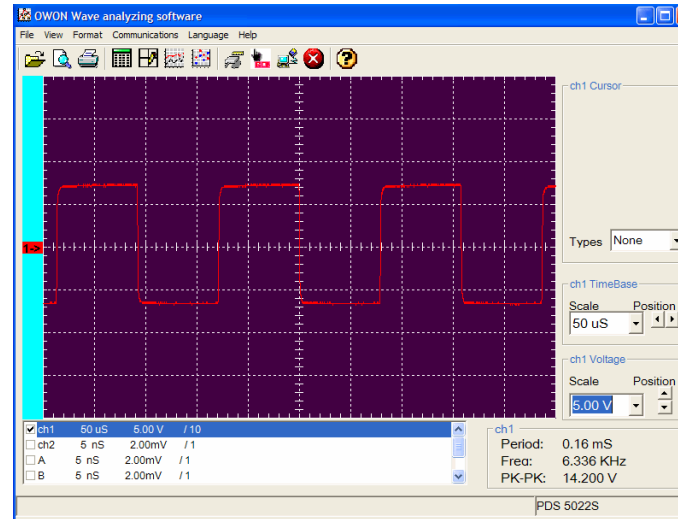

Figure 3. IC1-B output

multiplier (Reference 1) in the form of an amplifier with a gain of either +1 (switch closed) or -1 (switch open). The switch is controlled by the PWM output from IC1-B; the switch is closed when IC1-B's output is positive and open when IC1-B's output is negative. The resulting output from IC2-A (Figure 4) is a replica of the PWM output from IC1-B (duty cycle proportional to current), except with amplitude proportional to voltage.

IC2-B, the final stage of the circuit, is a low-pass filter which removes the 6 kHz PWM frequency and its harmonics as well as the 60 Hz modulation. Its output is proportional to the average of the PWM signal, and thus the average 60 Hz power.

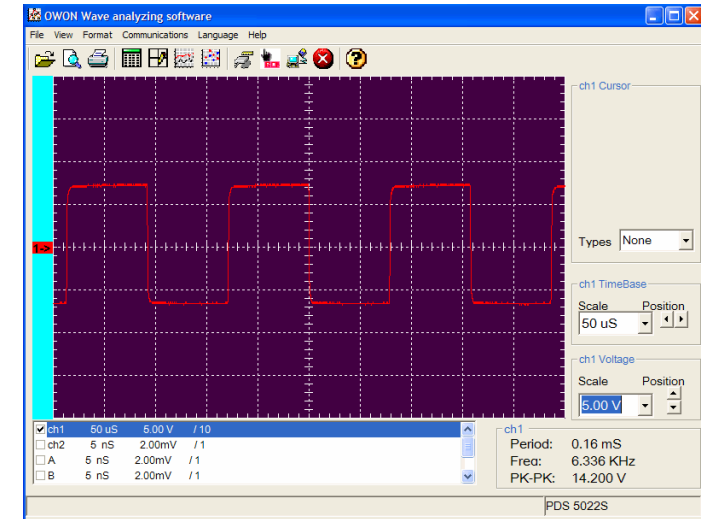

Figure 4. IC2-A output

### References:

Maxim Integrated, App. Note 4502, "Single IC PWM Modulator has 2% Linearity", Ahmad Ayar, Aug 10, 2010.

Maxim Integrated, App. Note 4281, "Advanced Power Line Monitoring Requires a High Performance Simultaneous Sampling ADC", Joseph Shtargot, Sept. 26, 2008

EDN Design Ideas, "Two IC-Circuit Combines Digital and Analog Signals to Make Multiplier Circuit", Rick Mally, Jan. 2013

## Fast, low-noise JFET amp is stable over temperature

By Shyam Sunder Tiwari



While JFETs are excellent devices for low-cost high-input impedance amplifiers, they do suffer from temperature-dependent gain drift. This problem can be ameliorated by setting the drain current to the zero-drift operating point over the -55C to 125C temperature range.

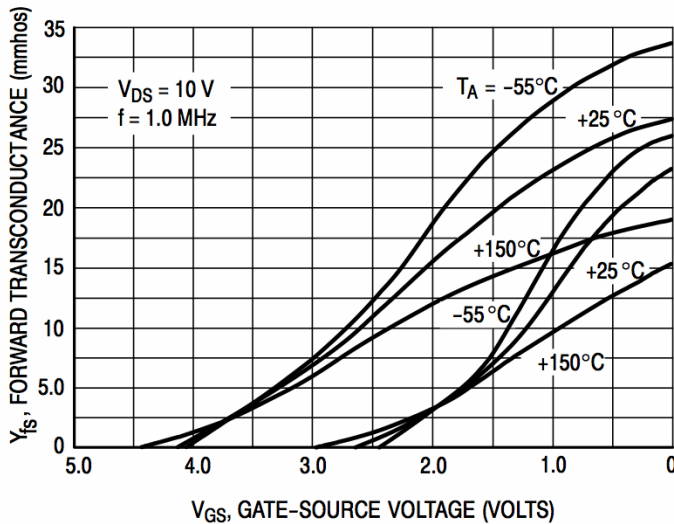

Figure 1. Transconductance curve families over temperature for J310 & J309 JFETs (OnSemi)

Various JFETs have been tested for this Design Idea circuit: Sony 2SK152-2, Interfet IFN152, and Siliconix/Vishay/OnSemi J309,

as they have high gain and a low gate leakage current of about 100 pA. These JFETs are well suited to 1 M $\Omega$ - to 1 G $\Omega$ -input impedance amplifier design. The circuit works well to over 100 MHz.

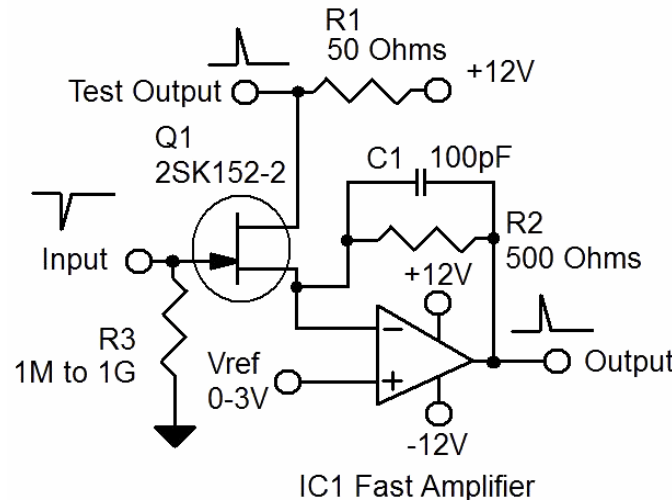

Figure 2. Very wide temperature range, gain-stable, fast JFET high-impedance amplifier

One advantage of the circuit comes from its large operating temperature range (-55C to 125C for the JFET). IC1 can be kept at room temperature, linked by a few feet of PTFE coax for example, for temperature isolation. Thus the JFET can be mounted in a very cool environ-

ment for lowest noise, which was a primary objective of the design.

The input signal to JFET Q1 is fed to its gate, which is biased to ground through R3 (which could be a lower value in the case of a current-source input).

The JFET's source is biased through the inverting current-to-voltage stage based on IC1.  $V_{ref}$ , which controls the quiescent  $V_{GS}$ , is set between 0V and 3V for most JFETs to set the drain current at the zero-drift midpoint, which also gives a large dynamic range for the input signal. By adjusting  $V_{ref}$ , we can bring Q1's operating current to about 7 mA-10mA, which is close to the zero-drift point. The operating current has to be separately analysed for each JFET to be set properly. For the 2SK152-2, it was found to be 7.5 mA  $\pm$  1 mA for the 1,000 JFETs I have tested.

IC1 is a fast CFA (current-feedback amplifier): Analog Devices' AD812 at  $\pm 12V$  to  $\pm 15V$ , and AD8009 at  $\pm 5V$ , have been used successfully. The feedback resistor R2 can be from 500 $\Omega$  to 5 k $\Omega$ , in parallel with C1 of 100 pF to avoid oscillations and overshoot. Remember that the output of the amplifier has a voltage offset due to the biased input stage and hence is best suited to AC or pulsed signals. A risetime of 10 nsec to 100 nsec is feasible with the proper R2/

C1 combination. CFAs are operated within a gain range of 2-10, set by resistor R2; at much higher gains, the amplifier starts oscillating.

R1 provides a test output to measure the current through the JFET. It also generates a fast 50Ω output which can be directly connected to an oscilloscope. Both output signals are inverted compared to the input signal – typically ±100 mV. For DC-biased signals, a coupling capacitor of about 1 nF-10 nF can be used in front of the gate.

### About the author

A company Managing Director, the author lives in the small city of Gwalior, MP, India. “I am a Physicist by education, Nuclear Scientist by Training, Electronics and Software professional by work. I am right now planning sensors and monitoring systems for water resource management and also developing technology to kill pathogens in water / fluids by nano-second high voltage discharge pulses. Good quality drinking water is my primary concern right now. Some of our current work can be seen at [www.asro.in](http://www.asro.in)



**Subscribe to the  
EDN Europe Daily Newsletter  
[www.edn-europe.com/newsletter](http://www.edn-europe.com/newsletter)**



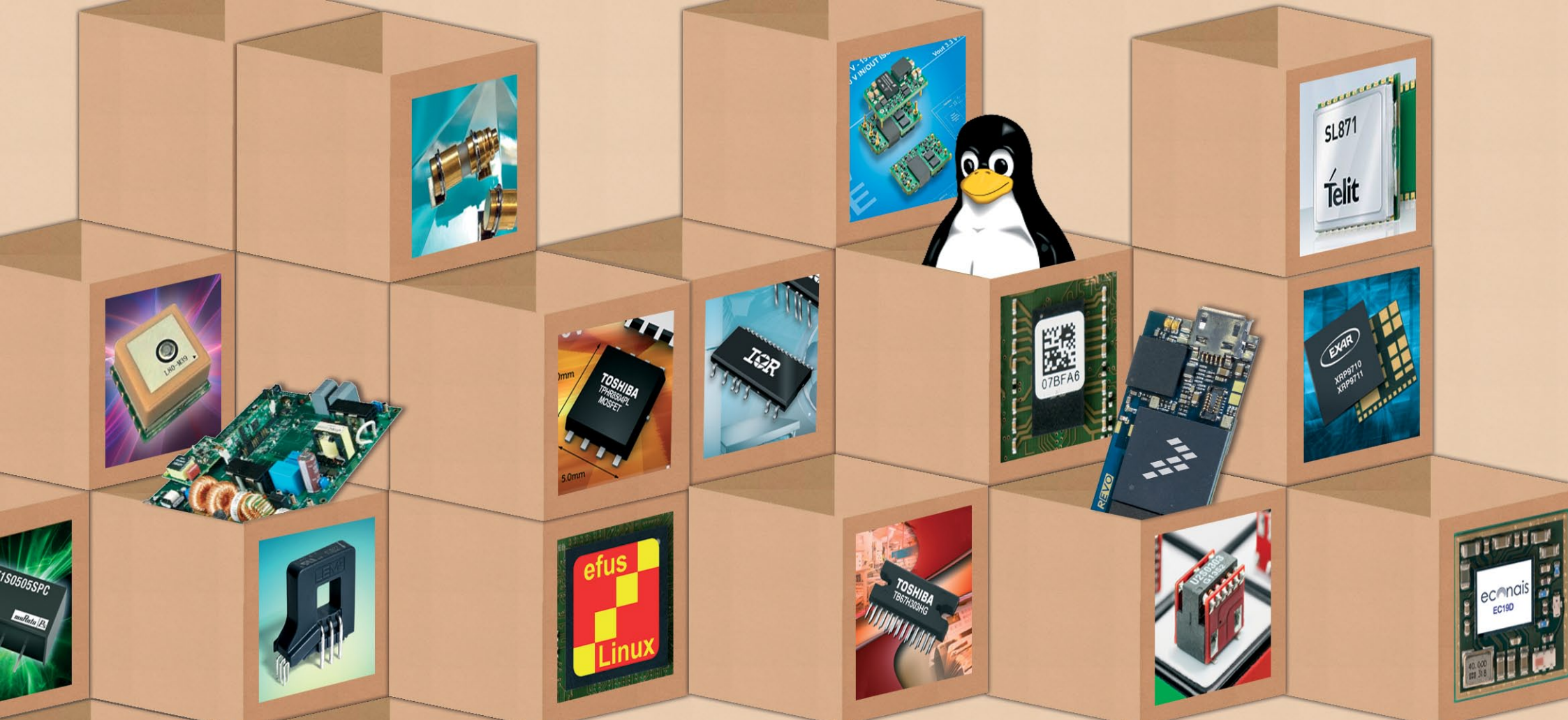

# productroundup





## “Near-perfect” 600V power FETs - ST

STMicroelectronics has extended its MDmesh M2 series of N-channel power MOSFETs with a family of devices that offer the highest power efficiencies in power supplies, especially under light-load conditions.

These 600V MDmesh M2 EP devices combine ST’s strip layout with an improved vertical structure and an optimised diffusion process to approach the ideal switch, with very low ON-resistance and the lowest available turn-off switching losses. They are tailored for very-high-frequency converters (switching frequencies of over 150 kHz).

600V MDmesh M2 EP MOSFETs



[Complete article, here](#)



## High-current sensors target HEV and mild-hybrid power trains

Melexis has added to its IMC-Hall Advanced current sensor portfolio; designed for the very high fields that characterise hybrid and electric vehicle (HEV) applications, the MLX91208CAV can cope with up to 1000A of primary current. Using integrated magnetic concentrator (IMC) technology, the sensors in the AEC-Q100-qualified MLX91208 series can accurately measure current without the need for inclusion of the bulky external ferromagnetic cores that are required for conventional Hall-effect current sensors.

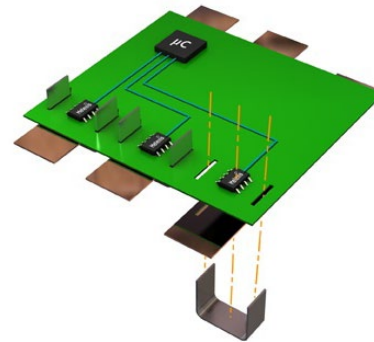

[Complete article, here](#)



## Cortex-M-based MCUs for connected-device designs

Toshiba’s TXZ family has low-power consumption and high-speed operation for IoT and M2M designs. The TXZ family integrates the ultra-low power design technologies from Toshiba’s TZ series of ApP Lite application processor family for IoT solutions, into the current TX family of microcontrollers. The first product group will be the TMPM3H, part of the TXZ3 series that will be based on the ARM Cortex-M3 core. The TMPM3H group will feature products characterised by small packages with pin counts of 32-100 pins, and flash memory capacities of 32 kB-128 kB.



[Complete article, here](#)



## Battery pack monitor IC for multi-cell Li-ion batteries

Intersil’s ISL94203 is a 3-to-8 cell battery pack monitor that supports lithium-ion (Li-ion) and other battery chemistries. The device has been designed to accurately monitor, protect and cell-balance rechargeable battery packs to maximise battery life and ensure safe charging and system operation. It functions as a stand-alone battery management system for rechargeable Li-ion battery packs. Its internal state machine has five pre-programmed stages that accurately control each cell of a battery pack to extend operating life. The IC integrates high-side charge/discharge FET drive circuitry.



[Complete article, here](#)







# productroundup

## Ultralow power buck regulator for wearables, IoT

Analog Devices' ADP5301 ultralow power buck regulator is intended to extend battery life in portable products by achieving the highest-available ultra-light-load power conversion efficiency. With a 90% efficiency rating and consuming 180 nA quiescent current, the buck regulator has 6.5-V to 2.05-V input voltage range; selectable, low-noise forced PWM mode with low output voltage ripple powers noise-sensitive analogue loads up to 500 mA. The output voltage is set by resistor selection, in two factory-option ranges of 1.2 to 3.6V, or 0.8 to 5.0V.

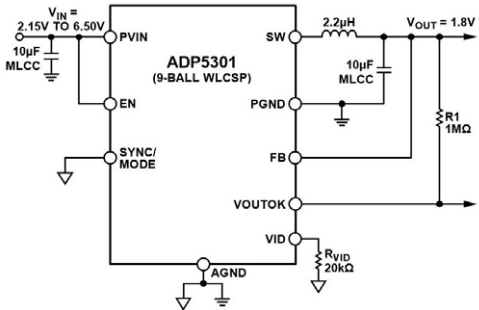

Complete article, here

## Precision VID regulator supplies FPGAs, ASICs & processors at up to 300A

LTC3877 is a dual output multiphase synchronous step-down DC/DC controller with 6-bit voltage identification (VID) control that enables 10mV output voltage step resolution, a necessary feature when powering FPGAs and ASICs with tight input voltage requirements. A multiphase DC/DC controller with 6-bit VID,  $\pm 1\%$  VOUT accuracy and  $\pm 2.5\%$  phase current matching, the LTC3877 operates over an input voltage range of 4.5V to 38V and produces a fixed output voltage from 0.6V to 1.23V when using VID and up to 5V without VID. Up to 12 phases can be paralleled.

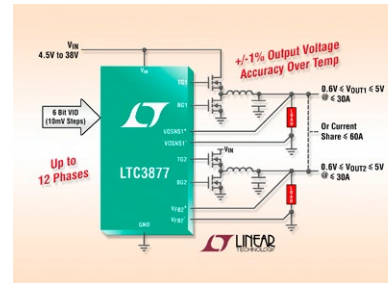

Complete article, here

## USB 3.0 to Gigabit Ethernet; controller for laptops, docking stations

This high-throughput, low-power USB 3.0 controller is designed to bring seamless connectivity to laptops and docks; Cypress' EZ-USB GX3 controller is specifically aimed at products migrating to thin USB Type-C ports. The SuperSpeed USB controller converts Gigabit Ethernet (GigE) data to USB 3.0 data. GX3 provides comprehensive driver support for all major operating systems, enabling seamless plug-and-play operation via a USB 3.0 port on any system, including laptops, tablets, docking stations, IP set-top boxes and smart TVs.

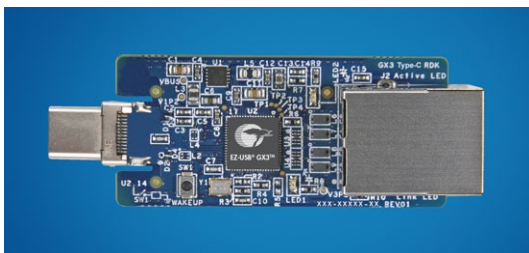

Complete article, here

## Bluetooth module for IoT connectivity

Silicon Labs' Blue Gecko BGM111 module comes with a pre-installed BLE (Bluetooth Low Energy) stack, and its scripting language provides a plug-and-play solution with an SoC migration path to Blue Gecko system-on-chip (SoC) solutions. This fully integrated, pre-certified Bluetooth Smart module gives developers a fast path to low-power wireless connectivity for the IoT. The BGM111 modules are pre-loaded with the Bluegiga Bluetooth 4.1-compliant software stack and profiles and are field-upgradable using device firmware upgrades to Bluetooth 4.2 and beyond.



Complete article, here





# productroundup

## 3D printer accepts multiple filament materials

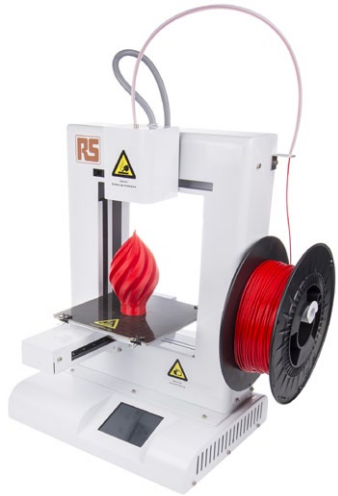

Positioned as affordable and providing professional-quality rapid prototyping, the IdeaWerk Pro 3D printer from RS Components costs £590 (UK Pounds, or equivalent). The RS IdeaWerk Pro is capable of handling multiple types of filaments, including Flexible, PLA, ABS, PA/NYLON, PC, HIPS and PVA. Features include: build volume of 150 x 150 x 140 mm; minimum layer resolution of 0.18mm; and maximum print speed of 30 mm<sup>3</sup> per hour. It features a heated bed that can handle 0 to 120°C and high-temperature extrusion up to 300°C.

Complete article, here

## Raspberry Pi/Matlab/Simulink bundle

Farnell element14 is listing a package that puts together MATLAB and Simulink Student Suite software with a complete starter kit of Raspberry Pi hardware. The MATLAB and Simulink Student Suite – Raspberry Pi Bundle includes the Raspberry Pi Starter Kit and the MATLAB and Simulink Student Suite from MathWorks, allowing the student or self learner to start a project with model-based block diagrams on the Raspberry Pi 2 using the same tools commercial engineers and scientists use every day.



Complete article, here

## 2-pin, self-powered serial EEPROMs

Using a parasitic power scheme and I<sup>2</sup>C signalling, these single-wire memories require just one data and one ground pin, eliminating the need for power source/Vcc; they present a plug-and-play 64-bit serial number for identification. Atmel aims the parts at wearables, consumable, battery and cable identification markets. The devices are self-powered,

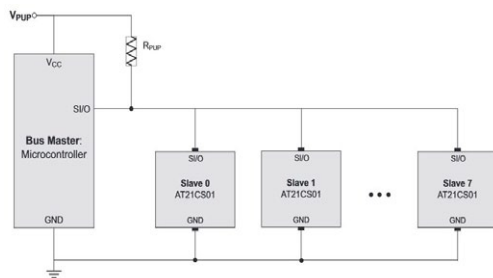

eliminating the need for a power source or Vcc pin, with a parasitic power scheme via the data pin. These devices draw ultra-low currents at standby of 700 nA: operating currents are 200 µA for write and 80 µA for read at 25C.

Complete article, here

## Surface mount MEMS angular acceleration sensor

Murata believes it has the first-available surface mount MEMS angular acceleration sensor, to meet demand for angular acceleration sensors with compact dimensions, which also feature high sensitivity, low noise and wide frequency band. With dimensions of 5.2 x 2.5 x 0.8 mm max. It supports a detection frequency band of more than 1 kHz and

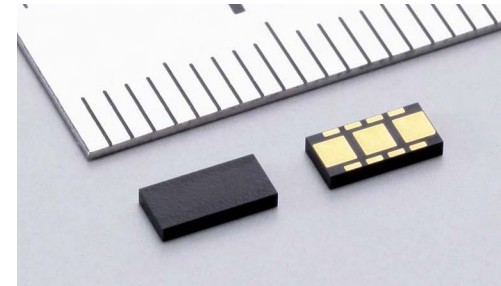

an angular acceleration equivalent noise effective value of less than 1 rad/s<sup>2</sup>ms. The surface mount MEMS angular acceleration sensor can be used for the detection of angular acceleration and the detection of rotational vibration.

Complete article, here



## Smallest true-bipolar $\pm 5V$ , 16-bit ADC

Maxim Integrated's MAX11166 is a 16-bit, 500 ksample/sec, SAR ADC that offers AC and DC performance with true bipolar input range, small size, and internal reference. It measures a  $\pm 5V$  (10 V<sub>p-p</sub>) input range while operating from a single 5V supply. A charge-pump architecture allows direct sampling of high-impedance sources. The

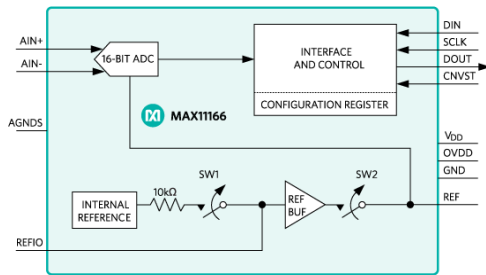

MAX11166 integrates an optional internal reference and buffer, achieving 92.9 dB SNR and -103 dB THD. The MAX11166 guarantees 16-bit no-missing codes and  $\pm 0.4$  LSB INL (typical). It communicates using an SPI-compatible interface.

Complete article, here

## LVDT-on-PCB inductor sensor interfaces

The first device in new family of smart sensor interface ICs, Microsemi's LX3301A is, says the company, the first inductive sensor IC based upon LVDT (linear variable differential transformer) architecture implementations on PCBs: Microsemi designed it for automotive and

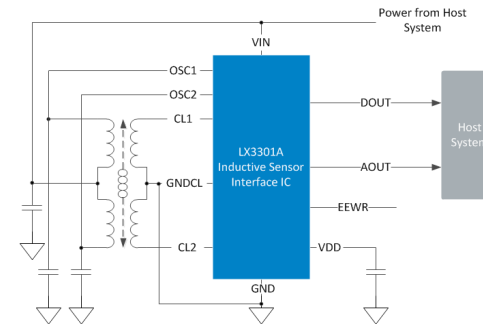

industrial applications. The LX3301A sensor interface IC's use of LVDT principles gives superior immunity to noise and interference. Microsemi says its technology can replace Hall-effect sensors; inductive technology eliminates magnets, thereby improving immunity to interference.

Complete article, here

## Low profile porous copper heatsinks

Materials specialist Versarien has developed heatsink products in which a microporous structure maximises surface area and enables more effective heat dissipation in space constrained designs.

LPH00xx series heatsinks are offered in form factors that cover 10 x 10 x 2 mm through to 40 x 40 x 5 mm; LPH00xx heatsinks can outperform comparable solutions by up to 6°C/W. For an applied load of 5W the thermal resistance of a LPH0010 (40 x 40 x 5 mm) heatsink is 17.4°C/W, while for a 2W load the thermal resistance of the LPH0004 (20 x 20 x 5 mm) product is 35.8°C/W.

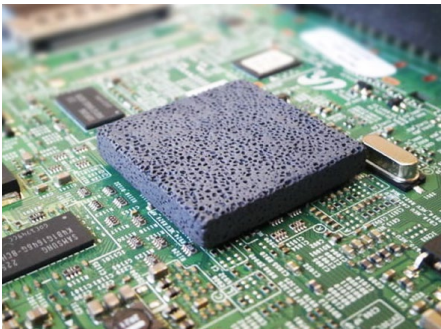

Complete article, here

## 9D motion tracking development kit

Distributor Mouser Electronics has the MTi 1-Series Development Kit from Xsens. This motion-tracking kit includes the MTi 1-series Development Board, a mounted MTi-3-8A7G6 module, USB cable, and MT Software Suite with software development kit for Windows and Linux.



The Xsens kit ships with a pre-mounted MTi-3-8A7G6 attitude and heading reference system (AHRS) module, which processes motion, magnetic field, roll/pitch, heading, and reference yaw. It includes a 3D accelerometer/gyroscope combo-sensor, a magnetometer, a high-accuracy crystal and a low-power MCU.

Complete article, here

## The downsides of tech complexity

An ongoing theme of many of my columns involves the downsides of complexity; by making technology too difficult for consumers to understand and implement, you're limiting your business opportunity both in the short term (due to customer returns) and long term (by shortchanging market adoption). A recent situation involving a friend of mine neatly exemplifies this situation. She's on the East Coast, whereas I'm in the middle of the country (USA), so my debugging was remote via email and phone conversations in combination with the efforts of a local technician (whose grasp of networking concepts wasn't stellar, but I digress ...).

My friend recently moved into a new residence, and was struggling with various network connectivity issues. Formerly served by Verizon FiOS service, the residence now gets broadband from Comcast, specifically via an [ARRIS Surf-Board gateway](#) (cable modem/router combo). The gateway is located in the first floor of the resi-

dence, whereas her office is in the basement and her bedroom is on the second floor. In both locations, her Internet connectivity was hit-and-miss; even when she was seemingly online, she sometimes couldn't "see" other LAN clients. Eventually (and time-inefficiently, since I was debugging from afar), after fruitlessly searching for interference sources in the form of neighbours' access points, changing Wi-Fi broadcast channels, and doing other basic troubleshooting steps, here's what I discovered:

The gateway supports dual-band 802.11n. Her laptop was prioritising the 5 GHz band's SSID, but (no surprise to engineers in the audience) the 5 GHz coverage was more restrictive than that of the 2.4 GHz Wi-Fi alternative. However, once the laptop grabbed the 5 GHz signal, it would stubbornly cling to

it even in the absence of robust SNR (signal/noise ratio). Bafflingly, the router's DHCP server supported different subnets for each Wi-Fi channel. When connected to 2.4 GHz, she was assigned an IP address in the 10.0.0.xxx range; conversely, when connected to 5 GHz, she got a 192.168.5.xxx assignment. This is why other LAN equipment, also with either 10.0.0.xxx or 192.168.5.xxx sub-



net IP addresses, would appear and disappear on a seemingly (to her) random basis. Although this situation might be understandable to a hard-core techie, I hope you can comprehend how bewildering it might be to a typical consumer. And although we could have fixed it in the short term by deleting the 5 GHz SSID information from her laptop's network settings, the coverage and IP address assignment problems would inevitably resurface with future LAN clients. So I chose a brute-force alternative, since

she really didn't need the 5 GHz band's bandwidth potential and the 2.4 GHz band was fairly interference free: I completely disabled the gateway's 5 GHz wireless radio subsystem.

My solution might have been in the spirit of "If you only have a hammer, you tend to see every problem as a nail," but it was effective. It didn't have to be this way, however. Simply telling a consumer that the gateway broadcasts two wireless signals, one potentially faster than the other but also more limited in its range, would have gone a long way. And the gateway's funky dual-subnet behaviour should get tossed, too. Putting yourself in the shoes of your customer and accordingly developing the product's feature set, documentation, configuration software, and other characteristics is one of the most challenging aspects of engineering, because it requires you to step back from a product-proximity situation in which you're naturally intimate. But market success necessitates that you do so, both directly and by fully embracing the feedback from in-market prototype testing.



# EDN

## europe

**EDN-EUROPE** is published 11 times in 2015 by **European Business Press SA**, 533 Chaussée de Louvain, 1380 Lasne, Belgium  
Tel: +32-2-740 00 50 Fax: +32-2-740 00 59  
email: [info@eetimes.be](mailto:info@eetimes.be).  
VAT Registration: BE 461.357.437.  
RPM: Nivelles.  
It is free to qualified engineers and managers involved in engineering decisions – see: <http://www.edn-europe.com/subscribe>  
Copyright 2015 by European Business Press SA.  
All rights reserved. P 304128

### CONTACTS

#### PUBLISHER

André Rousselot  
+32 27400053  
[andre.rousselot@eetimes.be](mailto:andre.rousselot@eetimes.be)

#### CIRCULATION & FINANCE

Luc Desimpel  
[luc.desimpel@eetimes.be](mailto:luc.desimpel@eetimes.be)

#### EDITOR-IN-CHIEF

Graham Prophet  
+44 7733 457432  
[edn-editor@eetimes.be](mailto:edn-editor@eetimes.be)

#### ADVERTISING PRODUCTION & REPRINTS

Lydia Gijsegom  
[lydia.gijsegom@eetimes.be](mailto:lydia.gijsegom@eetimes.be)

Patrick Mannion  
Brand Director EDN Worldwide

#### ART MANAGER

Jean-Paul Speliers

#### ACCOUNTING

Ricardo Pinto Ferreira



European  
business press

### SALES CONTACTS

#### Europe

Daniel Cardon  
France, Spain, Portugal  
+33 688 27 06 35  
[cardon.d@gmail.com](mailto:cardon.d@gmail.com)

Nadia Liefsoens  
Belgium  
+32-11-224 397  
[n.liefsoens@fivemedia.be](mailto:n.liefsoens@fivemedia.be)

Nick Walker  
UK, Ireland, Israel,  
The Netherlands  
+44 (0) 1442 864191  
[nickjwalker@btinternet.com](mailto:nickjwalker@btinternet.com)

Victoria & Norbert Hufmann  
Germany, Austria,  
Eastern Europe  
+49 911 93 97 64 42  
[sales@hufmann.info](mailto:sales@hufmann.info)

Monika Ailinger  
Switzerland  
+41-41-850 4424  
[m.ailinger@marcomedia.ch](mailto:m.ailinger@marcomedia.ch)

Andrea Rancati  
Italy  
+39-02-284 6716  
[info@silvera.it](mailto:info@silvera.it)

Colm Barry & Jeff Draycott  
Scandinavia  
+46-40-41 41 78  
[jeff.draycott@womp-int.com](mailto:jeff.draycott@womp-int.com)  
[colm.barry@telia.com](mailto:colm.barry@telia.com)

#### USA & Canada

Todd A. Bria  
West  
+1 831 477 2075  
[tbria@globalmediasales.com](mailto:tbria@globalmediasales.com)

Jim Lees  
PA, NJ & NY  
+1-610-626 0540  
[jjm@leesmedia.com](mailto:jjm@leesmedia.com)

Steve Priessman  
East, Midwest,  
South Central  
& Canada  
+1-630-420 8744  
[steve@stevenpriessman.com](mailto:steve@stevenpriessman.com)

Lesley Harmoning  
East, Midwest,  
South Central  
& Canada  
+1-218.686.6438  
[lesleyharmoning@gmail.com](mailto:lesleyharmoning@gmail.com)

#### Asia

Keita Sato  
Japan  
+81-3-6824-9386  
[Mlshida@mx.itmedia.co.jp](mailto:Mlshida@mx.itmedia.co.jp)

Grace Wu  
Asian Sources Publications  
Asia  
(886-2) 2712-6877  
[wug@globalsources.com](mailto:wug@globalsources.com)

John Ng  
Asian Sources Publications  
Asia  
(86-755) 8828 – 2656  
[jng@globalsources.com](mailto:jng@globalsources.com)